



K.S. Institute of Technology, Bengaluru

Department of Computer Science and Engineering
Academic Year 2024-25 (EVEN Semester)
CONTENT BEYOND SYLLABUS REPORT

Sl. No	Name of the Staff	Semester	Subject Name	Subject code	Activity Name
II SEMESTER					
1	Mrs. Suma Rajesh A	II	Introduction to Python Programming	BPLCK205B	Content Beyond Report on Online Certification(Infosys Springboard)
2	Ms. Maddelabargavi	II	Introduction to Python Programming	BPLCK205B	Content Beyond Report on Online Certification(Infosys Springboard)
IV SEMESTER					
1	Dr.Vijayalaxmi Mekali	IV	Analysis and Design Of Algorithms	BCS401	Content Beyond Report on Study of advanced Algorithms: Bellman Ford Algorithm
2	Dr. Sowbhagya M P	IV	Analysis and Design Of Algorithms	BCS401	Content Beyond Report on Algorithmic Solutions: Design,Problem Solving(Online Certification)
3	Mrs.Sheba Jebakani	IV	Analysis and Design Of Algorithms	BCS401	Content Beyond Report on Online Certification(Infosys Springboard)
4	Mrs.Amrita R	IV	Microcontrollers	BCS402	Content Beyond Report on Analytical Demonstration of Peripheral Interfacing using ARM7
5	Mr. Vishvakiran R C	IV	Microcontrollers	BCS402	Content Beyond Report on Analytical Demonstration of Peripheral Interfacing using ARM7
6	Mrs.Kodur Srividya	IV	Microcontrollers	BCS402	Content Beyond Report on Demonstration of programs on ARM kit.
7	Mr.T Somasekhar Dr Soubhagya lakshmi Mrs.Suma rajesh	IV	Database Management Systems	BCS403	Content Beyond Report MINI-PROJECT EXHIBITION

8	Dr. Jalaja p Dr. Venkataramana BS Mrs. Rekha R	IV	Discrete Mathematical Structures	BCS405A	Content Beyond Report on Group Theory Applications in Cryptography
9	Ms.Namyapriya D	IV	UI/UX	BCS456C	Content Beyond Report on value added Certification on AI
10	Dr.Shobha	IV	Biology for Engineers	BBOC407	Content Beyond Report on Online Certification
11	Mrs.Amritha R	IV	Universal Human Values	BUHK408	Content Beyond Report on Poster making
12	Mrs.Kodur Srividya	IV	Universal Human Values	BUHK408	Content Beyond Report on Poster making
VI SEMESTER					
14	Mrs.Shruthi T S	VI	Cloud Computing	BCS601	Content Beyond Report on Online Certification(Infosys Springboard)
15	Mrs.Roopa O Deshpande	VI	Cloud Computing	BCS601	Content Beyond Report on Online Certification(Infosys Springboard)
16	Mr.Prashanth H S	VI	Cloud Computing	BCS601	Content Beyond Report on Online Certification(Infosys Springboard)
17	Mrs.Roopashree S V	VI	Machine Learning	BCS602	Content Beyond Report on value added Certification on ML
18	Mrs.Beena K	VI	Machine Learning	BCS602	Content Beyond Report on Online Certification(Infosys Springboard)
19	Dr.Sunita Chalageri	VI	Compiler Design	BCS613C	Content Beyond Report on Online Certification(Infosys Springboard)
20	Dr.Sowbhagya M P	VI	Compiler Design	BCS613C	Content Beyond Report on Online Certification(Infosys Springboard)
21	Mr.Abhilash L Bhat	VI	Advanced Java	BCS613D	Content Beyond Report on Online Certification(Infosys Springboard)
23	Mrs.V Manjula	VI	Renewable Energy Power Plants	BME654B	Content Beyond Report on Online Certification(Infosys Springboard)
24	Mrs.Ramya R	VI	Renewable Energy Power Plants	BME654B	Content Beyond Report on Online Certification(Infosys Springboard)

 Head of the Department
 Dept. of Computer Science & Engg
 K.S. Institute of Technology
 Bengaluru -560 109



CONTENT BEYOND SYLLABUS

Academic Year	2024-25 (EVEN)
Name of the Faculty	SUMA RAJESH A
Course Name /Code	Introduction to Python Programming / BPLCK205B
Semester/Section	II / A
Activity Name	Online Certification (Infosys Springboard)
Topic Covered	<ul style="list-style-type: none"> Introduction to Python, Advanced Python Topics, Functions in Python
No. of Participants	50
Objectives/Goals	To understand the basics of the python programming language.
ICT Used	E-Learning
Appropriate Method/Instructional materials/Exam Questions	
Infosys Springboard: Introduction to Python	
Relevant CO's	CO1, CO2, CO3, CO4, CO5
Relevant PO's	PO5, PO9, PO10, PO12
Significance of Results/Outcomes	Students were able to enhance python programs writing skills, Improved functional techniques, and programming fundamentals became strong.
Reflective Critique	<ul style="list-style-type: none"> Certification courses help students show and build their expertise in courses selected. It aims students to sharpen their skill sets and prepare well for their future career

Certificate Proof:

https://drive.google.com/drive/folders/1vc2f0-8ZqxdAgXMjdWO_xMKH4g4vMKsg?usp=sharing

Sample Certificate

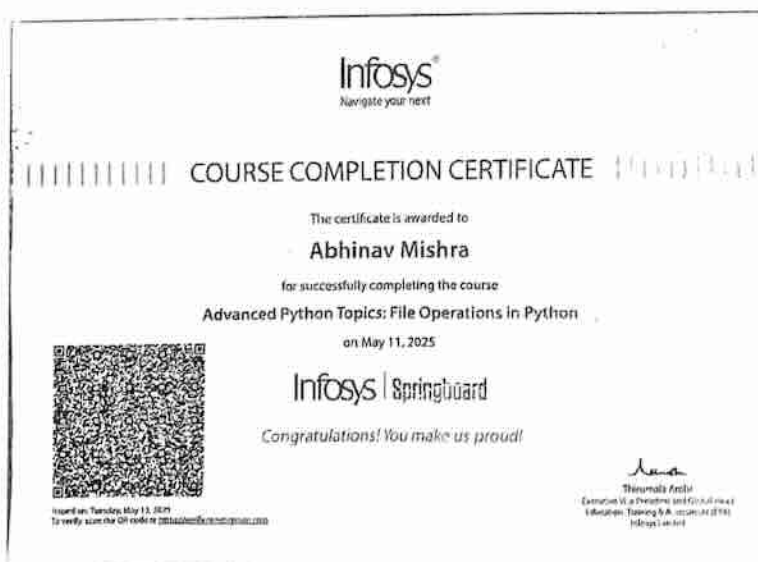



COURSE COMPLETION CERTIFICATE

The certificate is awarded to

Abhishek raghuram

for successfully completing the course

Functions in Python: Gaining a Deeper Understanding of Python Functions

on June 6, 2025

Infosys | Springboard

Congratulations! You make us proud!



Issued on: Saturday, June 7, 2025
To verify, scan the QR code at <https://edofccerts@infosys.com>

Thirumala Arathi
Executive Vice President and Global Head
Education, Training & Assessment (ETA)
Infosys Limited



Signature of the Course In-charge

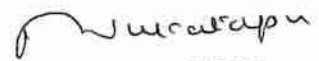

Signature of HOD



Online Course- Infosys Springboard completed by students

ACADEMIC YEAR:2024-2025

Semester / Section : II/ A

Sub: Learning Python ,Functions in Python , Advanced Python Topics: File Operations in python

Sl. No.	USN	Name	Platform	Date of Certification
1	1KS24CS001	A DIVYASHREE	Infosys Springboard	03/06/2025
2	1KS24CS002	ABHINAV MISHRA	Infosys Springboard	11/05/2025
3	1KS24CS003	ABHISHEK R	Infosys Springboard	06/06/2025
4	1KS24CS004	ADITHYA R RAIKAR	Infosys Springboard	24/05/2025
5	1KS24CS005	ADITI K	Infosys Springboard	02/06/2025
6	1KS24CS006	ADITYA	Infosys Springboard	06/06/2025
7	1KS24CS007	ANANYA	Infosys Springboard	03/06/2025
8	1KS24CS008	ANANYA B P	Infosys Springboard	10/06/2025
9	1KS24CS009	ANANYA K A	Infosys Springboard	02/06/2025
10	1KS24CS010	ANANYA MAHESH	Infosys Springboard	09/05/2025
11	1KS24CS011	ANANYA S P	Infosys Springboard	11/05/2025
12	1KS24CS012	ANUSHA CHANDRASHEKAR	Infosys Springboard	13/05/2025
13	1KS24CS013	ANUSHA G S	Infosys Springboard	11/05/2025
14	1KS24CS014	ANUSHA S	Infosys Springboard	05/06/2025
15	1KS24CS015	ANUSHA V	Infosys Springboard	02/06/2025
16	1KS24CS016	ANUSHAA J	Infosys Springboard	02/06/2025
17	1KS24CS017	ARBIYA FATHIMA	Infosys Springboard	27/05/2025
18	1KS24CS018	ARVIND GOWDA S N	Infosys Springboard	15/05/2025
19	1KS24CS019	ASHUTOSH KASHYAP	Infosys Springboard	13/05/2025
20	1KS24CS020	ASHWINI	Infosys Springboard	17/05/2025
21	1KS24CS021	ATHISH KASHYAPA	Infosys Springboard	05/06/2025
22	1KS24CS022	AVADHUT SAGAR CHOUGULE	Infosys Springboard	17/05/2025
23	1KS24CS023	BHAGYASHREE SINGE	Infosys Springboard	02/06/2025
24	1KS24CS024	BHARGAVI R	Infosys Springboard	14/05/2025
25	1KS24CS025	BINDHU SHREE H P	Coursera	12/05/2025
26	1KS24CS026	C G LIKHITH	Infosys Springboard	02/06/2025
27	1KS24CS027	CHANDAN K V	Infosys Springboard	13/06/2025
28	1KS24CS028	CHANDANA C S	Infosys Springboard	13/05/2025
29	1KS24CS030	CHEZHAN G H	Infosys Springboard	14/05/2025
30	1KS24CS034	DEEKSHA G R	Infosys Springboard	13/05/2025
31	1KS24CS037	DEEPA N	Infosys Springboard	11/05/2025
32	1KS24CS038	DEERAJ CHOWDARY NALADALA	Infosys Springboard	11/05/2025
33	1KS24CS039	DHANUSH R	Infosys Springboard	14/05/2025
34	1KS24CS041	DIVYA	Infosys Springboard	04/06/2025
35	1KS24CS042	ESHAN S	Infosys Springboard	13/05/2025
36	1KS24CS043	G J DHANUSH	Infosys Springboard	12/06/2025
37	1KS24CS044	GAGAN P HEGDE	Infosys Springboard	19/05/2025

38	1KS24CS045	GAGANA P	Infosys Springboard	15/05/2025
39	1KS24CS047	GANAVI U	Infosys Springboard	02/06/2025
40	1KS24CS048	HARSHAVARDHAN S	Infosys Springboard	19/05/2025
41	1KS24CS049	HARSHIT	Infosys Springboard	11/05/2025
42	1KS24CS050	HARSHITH V	Infosys Springboard	11/05/2025
43	1KS24CS051	HARSHITHA G P	Infosys Springboard	28/05/2025
44	1KS24CS052	HASINI K N	Infosys Springboard	31/05/2025
45	1KS24CS053	HEMANTH A G	Infosys Springboard	08/06/2025
46	1KS24CS054	HEMASHREE G	Coursera	09/05/2025
47	1KS24CS055	HIMA MOHAN	Infosys Springboard	17/05/2025
48	1KS24CS056	HOYSAL RAJ KUMAR P	Infosys Springboard	14/05/2025
49	1KS24CS057	J RITHVIK	Infosys Springboard	12/05/2025
50	1KS24CS058	JAHNAVI M N	Infosys Springboard	11/05/2025



Signature of Faculty-Incharge

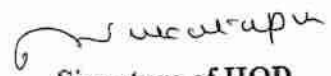

Signature of HOD



TEACHING AND LEARNING

CONTENT BEYOND SYLLABUS

Academic Year	2024-25 (EVEN)
Name of the Faculty	Asha Sattigeri
Course Name /Code	BPLCK205B
Semester/Section	II / B
Activity Name	Online Certification (Infosys Springboard)
Topics Covered	All the modules
No. of Participants	
Objectives/Goals	<ul style="list-style-type: none">• To understand the topic more precisely• To improve the self-learning skills of the students
ICT Used	E-Learning
Appropriate Method/Instructional materials/Exam Questions Infosys Springboard: Learning Python	
Relevant CO's	CO1, CO2, CO3, CO4, CO5
Relevant PO's	PO1, PO2, PO3, PO5, P012, PSO1
Significance of Results/Outcomes	Students were able to understand the concepts of Python and its applications.
Reflective Critique	<ul style="list-style-type: none">• Certification courses help students show and build their expertise in courses selected.• It aims students to sharpen their skill sets and prepare well for their future career.



TEACHING AND LEARNING

CONTENT BEYOND SYLLABUS

Academic Year	2024-25 (EVEN)
Name of the Faculty	Asha Sattigeri
Course Name /Code	BPLCK205B
Semester/Section	II / B
Activity Name	Online Certification (Infosys Springboard)
Topics Covered	All the modules
No. of Participants	
Objectives/Goals	<ul style="list-style-type: none">• To understand the topic more precisely• To improve the self-learning skills of the students
ICT Used	E-Learning
Appropriate Method/Instructional materials/Exam Questions Infosys Springboard: Learning Python	
Relevant CO's	CO1, CO2, CO3, CO4, CO5
Relevant PO's	PO1, PO2, PO3, PO5, P012, PSO1
Significance of Results/Outcomes	Students were able to understand the concepts of Python and its applications.
Reflective Critique	<ul style="list-style-type: none">• Certification courses help students show and build their expertise in courses selected.• It aims students to sharpen their skill sets and prepare well for their future career.

Certificate Proof:

<https://drive.google.com/drive/u/2/folders/1nZExXMLsWp92V60Y4h5IYi5Q7G1dKync>

Sample Certificate



[Handwritten Signature]
Signature of the Course In-charge

[Handwritten Signature]
Signature of HOD
Head of the Department
Dept. of Computer Science & Engg
K.S. Institute of Technology
Bengaluru - 560 109



K.S. INSTITUTE OF TECHNOLOGY, BANGALORE – 560109

DEPARTMENT OF COMPUTER SCIENCE & ENGINEERING



Online Course- Infosys Springboard completed by students

ACADEMIC YEAR:2024-2025(EVEN SEMESTER)

Year/Semester/Section: I/II/B

Subject: Introduction to Python Programming

Sl. No.	USN	Students Name	Platform	Details Of Certification	Date of Certification
1	IKS24CS059	JAYAKRISHNA S H	Infosys Springboard	Learning Python	27/04/2025
2	IKS24CS060	JEEVITHA P A	Infosys Springboard	Learning Python	26/04/2025
3	IKS24CS061	JEEVITHA R	Infosys Springboard	Learning Python	26/04/2025
4	IKS24CS062	K C SURESH NAIDU	Infosys Springboard	Learning Python	08/05/2025
5	IKS24CS064	KAVANA B	Infosys Springboard	Learning Python	26/04/2025
6	IKS24CS065	KEERTHANA S M	Infosys Springboard	Learning Python	08/05/2025
7	IKS24CS066	KEERTHI DEVARAJU	Infosys Springboard	Learning Python	26/04/2025
8	IKS24CS067	KISHOR C	Infosys Springboard	Learning Python	28/04/2025
9	IKS24CS068	KUSUMITHA N	Infosys Springboard	Learning Python	26/04/2025
10	IKS24CS069	LIKHITHASHREE G B	Infosys Springboard	Learning Python	20/04/2025
11	IKS24CS070	LIKITH GOWDA N	Infosys Springboard	Learning Python	02/05/2025
12	IKS24CS071	LOCHANA G T	Infosys Springboard	Learning Python	23/04/2025
13	IKS24CS072	MANASVI D S	Infosys Springboard	Learning Python	30/04/2025
14	IKS24CS073	MANISH KUMAR SINGH	Infosys Springboard	Learning Python	28/04/2025
15	IKS24CS074	MANOJ G L	Infosys Springboard	Learning Python	28/04/2025
16	IKS24CS075	MANOJ S	Infosys Springboard	Learning Python	29/04/2025
17	IKS24CS078	MOHAMMED AMEEN	Infosys Springboard	Learning Python	01/05/2025
18	IKS24CS079	MOHAMMED FAZAL	Infosys Springboard	Learning Python	28/04/2025
19	IKS24CS080	MOHAMMED MUSHREF	Infosys Springboard	Learning Python	08/05/2025
20	IKS24CS081	N GOKUL	Infosys Springboard	Learning Python	01/05/2025
21	IKS24CS082	N SUYOG	Infosys Springboard	Learning Python	27/04/2025
22	IKS24CS083	NAMA RAMCHAND	Infosys Springboard	Learning Python	27/04/2025
23	IKS24CS084	NANDINI M	Infosys Springboard	Learning Python	27/04/2025

53	1KS24CS114	PUSHPALATHA S	Infosys Springboard	Learning Python	23/04/2025
54	1KS24CS115	RAJESHWARI BANDIVADDAR	Infosys Springboard	Learning Python	28/04/2025
55	1KS24CS116	RAKSHITH S	Infosys Springboard	Learning Python	27/04/2025
56	1KS24CS117	RAKSHITHA K L	Infosys Springboard	Learning Python	28/04/2025

Signature of Faculty-In charge

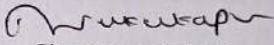
Signature of HOD
Head of the Department
Dept. of Computer Science & Engg
K.S. Institute of Technology
Bengaluru -560 109



CONTENT BEYOND SYLLABUS REPORT

Academic Year	2024-2025(Even)
Name of the Faculty	Dr. Vijayalaxmi Mekali
Course Name /Code	Analysis and Design of Algorithms (BCS401)
Semester/Section	4 th A
Activity Name	Study of Advanced Algorithms: Bellman Ford Algorithm
Topic Covered	Bellman Ford Algorithm
No. of Participants	60/67
Objectives/Goals	<ul style="list-style-type: none"> To understand the Single source shortest path problem using Bellman Ford Algorithm. To improve the thinking capability of students

ICT Used	Projector
Appropriate Method/Instructional Materials/Exam Questions:	PPT
Relevant CO's	CO1, CO2, CO3, CO4, CO5
Relevant PO's:	PO3, PO4, PO5
Significance of Results/Outcomes	Students were able to understand the Concepts of Single source shortest path problem using Bellman Ford Algorithm.
Reflective Critique	<ul style="list-style-type: none"> Learning of Different methods to solve Single source shortest path problem. Analysing the algorithm's Time complexity helps the students to improve their self-capability thinking Advanced algorithms concepts teaching aim to help students sharpen their skill sets and prepare for the workplace. The activity provided a platform for students to apply their knowledge of Algorithms.

Proofs :

Sample copy of the PPT is attached

Bellman Ford Algorithm

- Given an weighted graph with V vertices numbered from 0 to V-1 and E edges, represented by a 2d array edges[i][j], where edges[i][j] = [u, v, w] represents a direct edge from node u to v having w edge weight. You are also given a source vertex src.
- Your task is to compute the shortest distances from the source to all other vertices. If a vertex is unreachable from the source, its distance should be marked as 108. Additionally, if the graph contains a negative weight cycle, return [-1] to indicate that shortest paths cannot be reliably computed.
- Examples:
- Input: V = 5, edges[i][j] = [[1, 3, 2], [4, 3, -1], [2, 4, 1], [1, 2, 1], [0, 1, 5]], src = 0
Output: [0, 5, 6, 6, 7]

• Explanation: Shortest Paths:

- For 0 to 1 minimum distance will be 5. By following path 0 → 1
- For 0 to 2 minimum distance will be 6. By following path 0 → 1 → 2
- For 0 to 3 minimum distance will be 6. By following path 0 → 1 → 2 → 4 → 3
- For 0 to 4 minimum distance will be 7. By following path 0 → 1 → 2 → 4



Bellman Ford Algorithm

65

• Input: $V = 4$, $edges[][] = [[0, 1, 4], [1, 2, -6], [2, 3, 5], [3, 1, -2]]$, $src = 0$

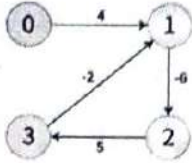

Output: [-1] Explanation: The graph contains a negative weight cycle formed by the path $1 \rightarrow 2 \rightarrow 3 \rightarrow 1$, where the total weight of the cycle is negative.

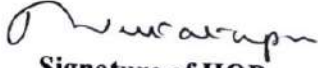

Signature of Course In charge

Signature of HOD
Head of the Department
Dept. of Computer Science & Engg.
K.S. Institute of Technology
Bengaluru -560 109



CONTENT BEYOND SYLLABUS REPORT

Academic Year	2024-2025(Even)
Name of the Faculty	Dr. Sowbhagya M P
Course Name /Code	Analysis and Design of Algorithms(BCS401)
Semester/Section	4 th
Activity Name	Online Certification
Topic Covered	Algorithmic solutions: Design, Problem solving
No. of Participants	28/35
Objectives/Goals	<ul style="list-style-type: none">• To understand the topic more precisely• To improve the self-learning skills of students
ICT Used	E-Learning
Appropriate Method/Instructional Materials/Exam Questions: Coursera: Algorithmic solutions: Design, Problem solving	
Relevant CO's	CO1,CO2,CO3,CO4,CO5
Relevant PO's:	PO9, PO10 ,PO12
Significance of Results/Outcomes	<ul style="list-style-type: none">• Students were able to understand the Concepts of Design and analysis of algorithms.
Reflective Critique	<ul style="list-style-type: none">• Certification courses help students show and build their expertise in <i>Courses selected</i>• Certification courses aim to help students sharpen their skill sets and prepare for the workplace.• The activity provided a platform for students to apply their knowledge of Design and analysis of algorithms.
Proofs : Sample copy of the certificate attached	

||||| COURSE COMPLETION CERTIFICATE |||||

The certificate is awarded to

RAVI CHANDRA K

for successfully completing the course

Beginning Java Data Structures and Algorithms

on June 2, 2025

Infosys | Springboard

Congratulations! You make us proud!



Awarded on: Wednesday, June 4, 2025
To verify, scan the QR code at <https://certify.amspringboard.com>

Thirumala Archi
Executive Vice President and Global Head
Education, Training & Assessments (ETA)
Infosys Limited

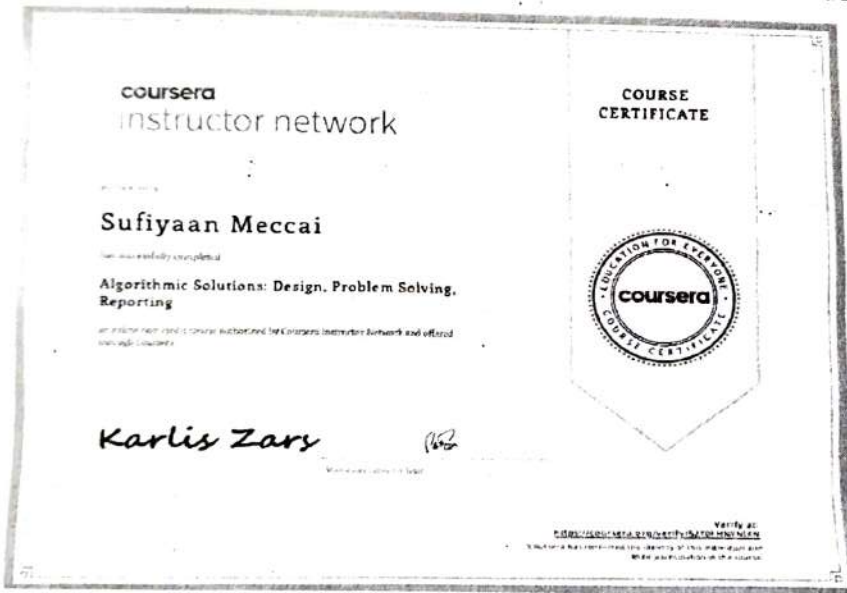

Signature of Course In charge

Signature of HOD
Head of the Department
Dept. of Computer Science & Engg
K.S. Institute of Technology
Bengaluru - 560 109



CONTENT BEYOND SYLLABUS REPORT

Academic Year	2024-25(EVEN)
Name of the Faculty	Mrs. Sheba Jebakani
Course Name /Code	Analysis and Design of Algorithms / BCS401
Semester/Section	IV C
Activity Name	Online Certification (NPTEL, udemy, Coursera Instructor Network)
Topic Covered	Design and Analysis of Algorithm MasterClass, Algorithmic Solutions: Design, Problem Solving,Reporting, Infosys springboard
No. of Participants	65
Objectives/Goals	<ul style="list-style-type: none">• To understand the topic more precisely• To improve the self-learning skills of students
ICT Used	E-Learning
Appropriate Method/Instructional Materials/Exam Questions:	<p>NPTEL: Design and Analysis of Algorithms Udemy: Design and Analysis of Algorithms Coursera Instructor Network : Design and Analysis of AlgorithmMasterClass, Algorithmic Solutions: Design, Problem Solving,Reporting, Infosys Springboard: Beginning Java Data Structures and Algorithms</p>
Relevant CO's	CO1,CO2,CO3,CO4,CO5
Relevant PO's:	PO9, PO10 ,PO12
Significance of Results/Outcomes	<ul style="list-style-type: none">• Students were able to understand the Concepts of ADA and its applications.• Students got exposed to NPTEL certification process.
Reflective Critique	<ul style="list-style-type: none">• Certification courses help studentsshow and build their expertise in <i>Courses selected</i>• Certification courses aim to help students sharpen their skill sets and prepare for the workplace.



Elite

NPTEL ONLINE CERTIFICATION

(Funded by the MoE, Govt. of India)

1K223C134



Skill India
शिक्षण भारत - कौशल भारत



This certificate is awarded to
SAHANA D
for successfully completing the course
Design and analysis of algorithms

with a consolidated score of **60** %

Online Assignments	21.88/25	Proctored Exam	38.25/75
--------------------	----------	----------------	----------

Total number of candidates certified in this course: 1696

Prof. Andrew Thangaraj
Chair
Centre for Outreach and Digital Education, IITM

Jan-Mar 2025
(8 week course)

Prof. Vignesh Muthuvijayan
NPTEL Coordinator
IIT Madras



Indian Institute of Technology Madras



Roll No. NPTEL25CS23S436404063

To verify the certificate



No. of credits recommended: 2 or 3

1K223C135

Infosys

Navigate your next.

COURSE COMPLETION CERTIFICATE

The certificate is awarded to
Sagarika Patil
for successfully completing the course
Beginning Java Data Structures and Algorithms
on June 4, 2025



Infosys | Springboard

Congratulations! You make us proud!

Thirumala Arora
Executive Vice President and Global Head
Education Training & Assessment (ETA)
Infosys Limited

Issued on: Thursday, June 5, 2025

1K523CS153

coursera
instructor network

COURSE
CERTIFICATE

May 01, 2025

SHRIHARI I B

has successfully completed

**Algorithmic Solutions: Design, Problem Solving,
Reporting**

an online non-credit course authorized by Coursera Instructor Network and offered
through Coursera



Karlis Zars

[Signature]

Signature of Instructor/Team

Verify at:
<https://coursera.org/verify/1K523CS153>
Coursera has verified the identity of this individual and
their participation in this course.

[Signature]

Signature of Course In charge

[Signature]

Signature of HOD
Head of the Department
Dept. of Computer Science & Engg
K.S. Institute of Technology
Bengaluru -560 100



K.S. INSTITUTE OF TECHNOLOGY, BANGALORE - 560109
DEPARTMENT OF COMPUTER SCIENCE AND ENGINEERING
TEACHING AND LEARNING

CONTENT BEYOND SYLLABUS REPORT

Academic Year	2024-2025(Even)
Name of the Faculty	Mrs. Amritha R.
Course Name /Code	Microcontrollers / BCS402
Semester/Section	IV/A
Activity Name	Analytical Demonstration of Peripheral Interfacing using ARM7 Microcontroller
Topic Covered	<ul style="list-style-type: none"> • LCD Display • 7 Segment display • Stepper Motor • DC Motor • Relay • 4 x 4 Keypad
No. of Participants	67
Objectives/Goals	<ul style="list-style-type: none"> • To bridge the gap between theoretical concepts and real-world embedded system applications. • To enhance students' understanding of ARM architecture, specifically the ARM7TDMI processor, through hands-on experiments. • To foster familiarity with peripheral interfacing, essential for embedded system design
ICT Used	<ul style="list-style-type: none"> • ARM7 LPC2148 EVALUATION BOARD (ALS-SDA-ARM7-06) • Keil μVision v4.74 • Flash magic v6.01
Appropriate Method/Instructional Materials/Exam Questions:	
<ul style="list-style-type: none"> • A demonstration was given using ARM7 LPC2148 Evaluation board & peripheral devices • Hands-on with industry-standard tools like: <ul style="list-style-type: none"> ○ Keil μVision ○ Flash Magic for flashing code ○ JTAG for debugging 	
Relevant CO's	CO1, CO2, CO3, CO5
Relevant PO's:	PO1, PO2, PO3, PO4, PO5, PO9, PO10, PO12
Significance of Results/Outcomes	<ul style="list-style-type: none"> • Students developed a concrete understanding of how software instructions control hardware components. • Exposure to components like LCDs, 7-segment displays, and motors

	<p>deepened their knowledge of practical interfacing.</p> <ul style="list-style-type: none"> The session provided a stepping stone toward advanced embedded platforms like ARM7, ARM Cortex-M and real-time operating systems and motors.
Reflective Critique	<ul style="list-style-type: none"> The hands-on activity effectively translated theoretical learning into tangible skills. Students gained direct exposure to embedded system debugging and hardware control. The use of the ARM7 LPC2148 Evaluation Board enriched their learning experience by allowing experimentation with real-world microcontroller peripherals.

Proofs :
Sample copy of photos attached



dy
Signature of Course In charge

M. Subashini
Signature of HOD
Head of the Department
Dept. of Computer Science & Engg
K. S. Institute of Technology
Bengaluru -560 109

1.1 MICROCONTROLLER FEATURES

Following are the features of 16 bit /32 bit LPC2148 Arm Microcontroller:

- PHILIPS LPC2148 is a 16-bit or 32-bit Microcontroller in a LQFP64-pin Package.
- 40 kB of on-chip static RAM and 512 kB of on-chip flash memory. 128-bit wide interface/accelerator enables high-speed 60 MHz operation.
- The LPC2148 provides 100000 erase/write cycles and 20 years of Data-retention.
- In-System Programming/In-Application Programming (ISP/IAP) via on-chip boot loader software. Single flash sector or full chip erase takes 400ms and Flash programming takes 1ms per 256-byte line.
- USB 2.0 Full speed compliant device controller with 2 kB of endpoint RAM. In addition, the LPC2148 provides 8 kB of on-chip RAM accessible to USB by DMA.
- Embedded ICE-RT and Embedded Trace Macro cell (ETM) interfaces offer real time debugging with on-chip Real Monitor software and high-speed real-time tracing of instruction execution.
- Two 10-bit ADCs provide a total of 14 analog inputs, with conversion times as low as 2.44 μ s per channel.
- Single 10-bit DAC provides variable analog output.
- Two 32-bit Timers/External event Counters (with four Capture and four Compare channels each), PWM unit (six outputs) and watchdog.
- Low power Real-Time Clock (RTC) with independent power and 32 kHz clock input.
- Multiple serial interfaces including two UARTs (16C550 equivalent), two Fast I2C-bus (400 kbit/s), SPI and SSP with buffering and variable data length capabilities.
- Vectored interrupt controller (VIC) with configurable priorities and vector addresses.
- Up to 45 numbers of 5 V tolerant fast general purpose I/O pins in a tiny LQFP64 package.
- Up to nine edge or level sensitive external interrupt pins available.
- 60 MHz maximum CPU clock available from programmable on-chip PLL with

settling time of 100 μ s.

- On-chip integrated oscillator operates with an external crystal in range from 1 MHz to 30 MHz and with an external oscillator up to 50 MHz.
- Power saving modes include Idle and Power-down.
- Individual power enable/disable of peripheral functions as well as peripheral clock scaling for additional power optimization.
- Processor wake-up from Power-down mode via external interrupt, USB, Brown-Out Detect (BOD) or Real-Time Clock (RTC).
- Single power supply chip with Power-On Reset (POR) and BOD circuits: CPU operating voltage range of 3.0 V to 3.6 V ($3.3 \text{ V} \pm 10 \%$) with 5 V tolerant I/O pads.

1.2 BOARD SPECIFICATIONS:

- LPC2148 16/32 BIT ARM7TDMI-S with 512K bytes Program Flash, 42K bytes RAM.
- 12MHz Crystal allows easy communication setup.
- One on board voltage regulator for generating 3.3V. Input to this will be from External +5V DC Power supply through a 9-pin DSUB connector.
- One RS232 interface circuits with 9 pin DSUB connector: this is used by the Boot loader program, to program LPC2148 Flash memory without external Programmer. Can also be used as a Serial port in applications
- Piggy Back module containing LPC2148 controller.
- Standard JTAG connector with ARM 2x10 pin layout for programming/debugging with ARM-JTAG.
- Standard 26-pin FRC connectors to connect to on-board interface or some of ALS standard External Interfaces.
- Reset push-button for resetting the controller.
- Onchip ADC interface circuit through a potentiometer.
- External interrupt0 interface using a key.
- External interrupt1 interface using a key with LED indication.

ARM7 Evaluation Board LPC2148 – Demonstration

- LCD 16x2 alphanumeric display.
- On-board eight push-button switches.
- 4x4 key matrix.
- Eight general purpose LED's: SMD 8 nos and THROUGH HOLE 8 nos.
- Four-digit multiplexed 7-segment display interface
- 8-bit DAC interface.
- Stepper motor interface with direction and speed control.
- DC motor interface with direction and speed control.
- Interface circuit for on board Buzzer and Relay.
- A number of software examples in 'C-language' to illustrate the functioning of the interfaces. The software examples are compiled using an evaluation version of KEIL4 'C' compiler for ARM.
- Compact elegant plastic enclosure.
- Serial RS232 cable is included.



INSTALLATION:

1.3 KEIL UVISION4 IDE INSTALLATION:

1. Installation of keilUvision4 as follows.
2. Go to Software folder in the CD and run Keil4 Arm.exe file.
3. Next
4. Click on the option "I agree to all the terms of..." and then give Next
5. Next
6. Give some name and the mail id and then Next
7. Click Finish to complete the installation.

1.4 PROJECT CREATION IN KEILUV4 IDE:

1. Create a project folder before creating NEW project.
2. Open Keil uVision4 IDE software by double clicking on "Keil Uvision4" icon.
3. Go to "Project" then to "New Project" and save it with a name in the Respective project folder, already you created.
4. Select the device as "NXP {founded by Philips}" In that "LPC2148" then press OK
5. and then press "YES" button to add "startup.s" file.
6. In startup file go to Configuration Wizard. In Configuration Wizard window disable PLL Setup and enable VPBDIV Setup.
7. Go to "File" In that "New" to open an editor window. Create your source file And use the header file "lpc21xx.h" in the source file and save the file. Colour syntax highlighting will be enabled once the file is saved with a Recognized extension such as ".C".
8. Right click on "Source Group 1" and select the option "Add Files to Group 'Source Group 1'" "add the .C source file(s) to the group.
9. After adding the source file you can see the file in Project Window.
10. Then go to "Project" in that "Translate" to compile the File (s).

11. Go to "Project" in that "Build Target" for building all source files such as ".C", ".ASM", ".h", files, etc. This will create the .HEX file if no warnings & no Errors.

1.5 Some Settings to be done in KEILUV4 for Executing C programs:

1. In Project Window Right click "TARGET1" and select "options for target 'TARGET1'"
 - Then go to option "Target" in that
 1. Xtal 12.0MHz
 2. Select "Use MicroLIB".
 3. Select IROM1 (starting 0x0 size 0x80000).
 4. Select IRAM1 (starting 0x40000000 size 0x8000).
 - Then go to option "Output"
 1. Select "Create Hex file".
 - Then go to option "Linker"
 1. Select "Use Memory Layout for Target Dialog".

1.6 FLASH MAGIC VERSION 6.01.2547:

Installation of Flash Magic as follows.

1. Go to Software folder in the CD and run FlashMagic.exe file.
2. Next
3. Click on the option "I Accept the Agreement" and then give Next
4. Then it asks the Destination location, Click Next.
5. Further Select start menu folder, Click Next.
6. Select "Create a desktop icon" then Next
7. It asks "Ready to Install" Click INSTALL.
8. Click Finish to complete the installation.

1.7 ISP PROGRAMMING:

FLASH MAGIC software can be used to download the HEX files to the Flash memory of controller.

How to Download?

Connect the serial cross cable from 9-pin DSUB Female connector (DB2) to the PC COM port. Switch on both buttons of SW11. SW11(1-RTS), SW11(2-DTR). Connect DC +5V Power, through the 9-pin DSUB FEMALE connector (DB1) applied from an external source. Switch ON the power.

1.8 Some Settings in FLASH MAGIC:

Step1. Communications:

1. Device : LPC2148
2. Com Port : COM1
3. Baud Rate : 9600
4. Interface : None(ISP)
5. Oscillator : 12MHz

Step2. ERASE:

1. Select "Erase Blocks Used By Hex File".

Step3. Hex file:

1. Browse and select the Hex file which you want to Download.

Step4. Start:

1. Click Start to download the hex file to the controller.

After downloading the code the program starts executing in the hardware, then remove the ISP jumper JP4.

Note: In FLASH MAGIC Go to Options and then in Advanced Options

- Select High Speed Communications (115200) in Communications tab.
- Select Use DTR & RTS to control RST & ISP Pin and Keep RTS asserted while COM Port open.

For all the programs make sure that the corresponding settings have to be made:

1. Both Switches of SW11 should be in ON position for ISP programming.
2. Short JP7 for ISP programming.
3. Short JP5 to connect +3.3v into the circuit.
4. Short JP4 to connect +5v to Interface Board.
5. Connect the 26 core FRC cable CN7 to CN8 to connect to External interfaces.
6. Connect CN7 for External NIFC's.

DEMONSTRATION 1: LCD DISPLAY

//////// "LCD DISPLAY" To display the predefined data //////////

```
#include<lpc214x.h>
#include<stdio.h>

//Function prototypes
void lcd_init(void);
void wr_cn(void);
void clr_disp(void);
void delay(unsigned int);
void lcd_com(void);
void wr_dn(void);
void lcd_data(void);
```

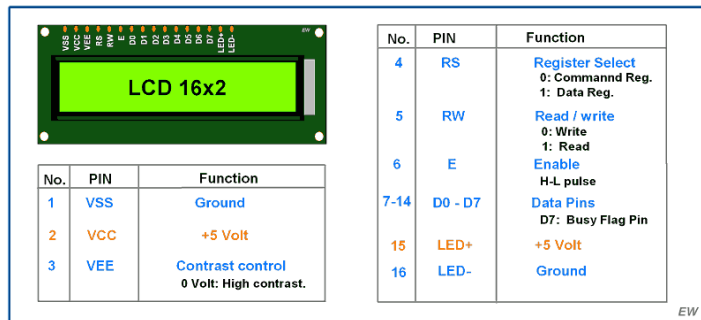

```
unsigned char temp1;
unsigned long int temp,r=0;
unsigned char *ptr,disp[] = "KSIT CSE Dept",displ[] = "BENGALURU-109";
```

```
int main()
{
    IOODIR = 0x000000FC;           //configure o/p lines for lcd
    IOOPIN = 0X00000000;

    delay(3200);                  //delay
    lcd_init();                   //lcd intialisation
    delay(3200);                  //delay
    clr_disp();                   //clear display
    delay(3200);                  //delay

    //.....LCD DISPLAY TEST.....//
    temp1 = 0x80;//Display starting address of first line 1st pos
    lcd_com();

    ptr = disp;
    while(*ptr!='\0')
    {
        temp1 = *ptr;
        lcd_data();
        ptr ++;
    }

    temp1 = 0xC0;// Display starting address of second line 4th pos
    lcd_com();

    ptr = displ;
    while(*ptr!='\0')
    {
        temp1 = *ptr;
        lcd_data();
        ptr ++;
    }
    while(1);
} //end of main()

// lcd initialisation routine.
void lcd_init(void)
{
    temp = 0x30;
    wr_cn();
    delay(3200);
```

```
temp = 0x30;
wr_cn();
delay(3200);

temp = 0x30;
wr_cn();
delay(3200);

temp = 0x20;    // change to 4 bit mode from default 8 bit mode
wr_cn();
delay(3200);

// load command for lcd function setting with lcd in 4 bit mode,
// 2 line and 5x7 matrix display

temp = 0x28;
lcd_com();
delay(3200);

// load a command for display on, cursor on and blinking off
temp1 = 0x0C;
lcd_com();
delay(800);

// command for cursor increment after data dump
temp1 = 0x06;
lcd_com();
delay(800);

temp1 = 0x80; // set the cursor to beginning of line 1
lcd_com();
delay(800);
}

void lcd_com(void)
{
    temp = temp1 & 0xf0;
    wr_cn();
    temp = temp1 & 0x0f;
    temp = temp << 4;
    wr_cn();
    delay(500);
}

// command nibble o/p routine
void wr_cn(void) //write command reg
{
    IOOCLR = 0x000000FC; // clear the port lines.
    IOOSET = temp; // Assign the value to the PORT lines
    IOOCLR = 0x00000004; // clear bit RS = 0
    IOOSET = 0x00000008; // E=1
    delay(10);
    IOOCLR = 0x00000008;
}

// data nibble o/p routine
void wr_dn(void) //write data reg
{
    IOOCLR = 0x000000FC; // clear the port lines.
    IOOSET = temp; // Assign the value to the PORT lines
    IOOSET = 0x00000004; // set bit RS = 1
```

```

        IOOSET = 0x00000008;          // E=1
        delay(10);
        IOOCLR = 0x00000008;
    }

// data o/p routine which also outputs high nibble first
// and lower nibble next
void lcd_data(void)
{
    temp = temp1 & 0xf0;
    temp = temp ;//<< 6;
    wr_dn();
    temp= temp1 & 0x0f;
    temp= temp << 4;
    wr_dn();
    delay(100);
}

void clr_disp(void)
{
// command to clear lcd display
    temp1 = 0x01;
    lcd_com();
    delay(500);
}

void delay(unsigned int r1)
{
    for(r=0;r<r1;r++);
}

```

DEMONSTRATION 2: 7 segment displays

```

#include <LPC21xx.h>

/*/////////////////////////////////DISPLAY ARE CONNECTED IN COMMON CATHODE
MODE/////////////////////////////////
Port0 Connected to data lines of all 7 segement displays
a = P0.10
b = P0.11
c = P0.12
d = P0.13
e = P0.18
f = P0.19
g = P0.20
dot = P0.21

Select lines for four 7 Segments
DIS1 P0.28
DIS2 P0.29
DIS3 P0.30
DIS4 P0.31

*/

unsigned int delay, count=0, Switchcount=0;
unsigned int Disp[16]={0x003F0000, 0x00060000, 0x005B0000, 0x004F0000,
0x00660000,0x006D0000, 0x007D0000, 0x00070000, 0x007F0000, 0x006F0000,
0x00770000,0x007C0000, 0x00390000, 0x005E0000, 0x00790000, 0x00710000 };

#define SELDISP1 0x10000000 //P0.28
#define SELDISP2 0x20000000 //P0.29
#define SELDISP3 0x40000000 //P0.30

```

7-Segment Display

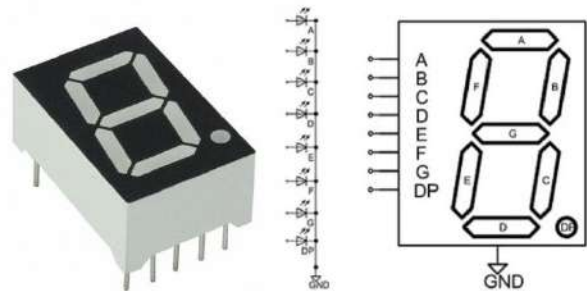

```
#define SELDISP4 0x80000000 //P0.31
#define ALLDISP 0xF0000000 //Select all display
#define DATAPORT 0x00FF0000
//P0.16 to P0.23 : Data lines connected to drive Seven Segments

int main (void)
{
    PINSEL0 = 0x00000000;
    PINSEL1 = 0x00000000;
    IOODIR = 0xF0FF0000;
    IO1DIR = 0x01000000;

    while(1)
    {
        //Display values on Seven Segment
        IOOSET |= ALLDISP;
        IOOCLR = 0x00FF0000;

        for(delay=0;delay<100;delay++)
            IOOSET = Disp[Switchcount];
        // display the values 0 to F one after the other
        for(delay=0;delay<1000000;delay++)
            {}

        Switchcount++;
        if(Switchcount == 16) // after F go back to 0
        {
            Switchcount = 0;
        }
    }
}
```

DEMONSTRATION 3: STEPPER Motor

```
#include <LPC21xx.H>

void clock_wise(void);
void anti_clock_wise(void);

unsigned long int var1, var2;
unsigned int i = 0, j = 0, k = 0;

int main(void) {
    PINSEL0 = 0x00FFFFFF; //P0.12 to P0.15 GPIO
    IOODIR |= 0x0000F000; //P0.12 to P0.15 output

    while (1) {
        for (j = 0; j < 50; j++) // 20 times in Clock wise Rotation
            clock_wise();

        for (k = 0; k < 65000; k++); // Delay to show anti_clock Rotation

        for (j = 0; j < 50; j++) // 20 times in Anti Clock wise Rotation
            anti_clock_wise();

        for (k = 0; k < 65000; k++); // Delay to show clock Rotation

    } // End of while(1)

} // End of main

void clock_wise(void) {
```

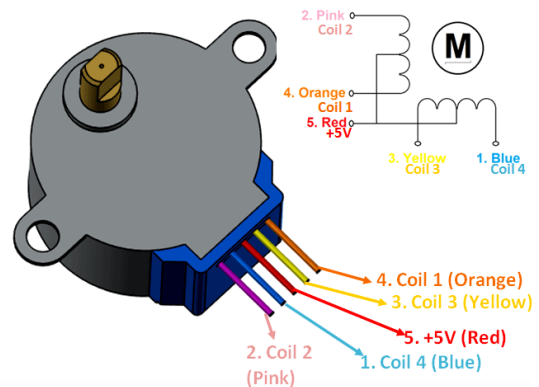

```
var1 = 0x00000800; //For Clockwise
for (i = 0; i <= 3; i++) // for A B C D Stepping
{
    var1 = var1 << 1; //For Clockwise

    IO0PIN = var1;

    for (k = 0; k < 3000; k++); //for step speed variation
}
}

void anti_clock_wise(void) {
    var1 = 0x00010000; //For Anticlockwise
    for (i = 0; i <= 3; i++) // for A B C D Stepping
    {
        var1 = var1 >> 1; //For Anticlockwise

        IO0PIN = var1;
        for (k = 0; k < 3000; k++); //for step speed variation

    }
}
```

DEMONSTRATION 4: DC Motor

```
#include<lpc214x.h>

void clock_wise(void);
void anti_clock_wise(void);
unsigned int j = 0;

int main() {
    IO0DIR = 0x00000900;
    IO0SET = 0x00000100; //P0.8 should always high.

    while (1) {
        clock_wise();
        for (j = 0; j < 400000; j++); //delay
        anti_clock_wise();
        for (j = 0; j < 400000; j++); //delay
    } //End of while(1)
} //End of Main

void clock_wise(void) {
    IO0CLR = 0x00000900; //stop motor and also turn off relay
    for (j = 0; j < 10000; j++); //small delay to allow motor to turn off
    IO0SET = 0x00000900; //Selecting the P0.11 line for clockwise and turn
on motor
}

void anti_clock_wise(void) {
    IO0CLR = 0x00000900; //stop motor and also turn off relay
    for (j = 0; j < 10000; j++); //small delay to allow motor to turn off
    IO0SET = 0x00000100; //not selecting the P0.11 line for Anti clockwise
}
```



DEMONSTRATION 5: Relay Switch

```
#include <LPC21xx.h>

unsigned int i;

int main ()
{
    IOODIR = 0x00000400;           //Set P0.10 as output
    IOOSET = 0x00000400;         //P0.10 is set to a HI

    while(1)
    {
        for(i=0;i<1000000;i++)
        {}
        IOOSET = 0x00000400;      //RLY ON
        for(i=0;i<1000000;i++)
        {}
        IOOCLR = 0x00000400;     //RLY OFF
    }
}
```

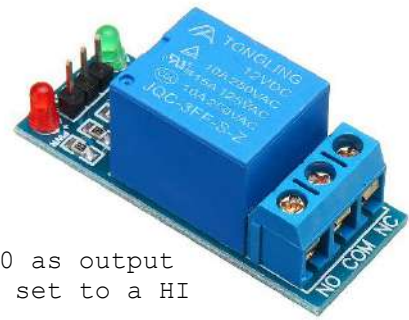

DEMONSTRATION 6: 4 x 4 key board

```
#include<lpc21xx.h>
#include<stdio.h>
void lcd_init(void);
void clr_disp(void);
void lcd_com(void);
void lcd_data(void);
void wr_cn(void);
void wr_dn(void);
void scan(void);
void get_key(void);
void display(void);
void delay(unsigned int);
void init_port(void);
unsigned long int scan_code[16] = { 0x00EE0000, 0x00ED0000, 0x00EB0000,
0x00E70000, 0x00DE0000, 0x00DD0000, 0x00DB0000, 0x00D70000,
0x00BE0000, 0x00BD0000, 0x00BB0000, 0x00B70000, 0x007E0000,
0x007D0000, 0x007B0000, 0x00770000};

unsigned char ASCII_CODE[16] = { '0', '1', '2', '3', '4', '5', '6',
'7', '8', '9', 'A', 'B', 'C', 'D', 'E', 'F'};

unsigned char row, col;
unsigned char temp, flag, i, result, temp1;
unsigned int r, r1;
unsigned long int
var, var1, var2, res1, temp2, temp3, temp4;
unsigned char * ptr, disp[] = "4X4 KEYPAD";
unsigned char disp0[] = "KEYPAD TESTING";
unsigned char disp1[] = "KEY = ";

int main() {
    // __ARMLIB_enableIRQ();
    init_port(); //port intialisation
    delay(3200); //delay
    lcd_init(); //lcd intialisation
    delay(3200); //delay
    clr_disp(); //clear display
    delay(500); //delay
    //.....LCD DISPLAY TEST.....//
    ptr = disp;
```



4x4 Matrix Keypad

```
temp1 = 0x81; // Display starting address
lcd_com();
delay(800);
while ( * ptr != '\0') {
    temp1 = * ptr;
    lcd_data();
    ptr++;
}
//.....KEYPAD Working.....//
while (1) {
    get_key();
    display();
}
} //end of main()
void get_key(void) //get the key from the keyboard
{
    unsigned int i;
    flag = 0x00;
    IO1PIN = 0x000f0000;
    while (1) {
        for (row = 0X00; row < 0X04; row++) //Writing one for col's
        {
            if (row == 0X00) {
                temp3 = 0x00700000;
            } else if (row == 0X01) {
                temp3 = 0x00B00000;
            } else if (row == 0X02) {
                temp3 = 0x00D00000;
            } else if (row == 0X03) {
                temp3 = 0x00E00000;
            }
            var1 = temp3;
            IO1PIN = var1; // each time var1 value is put to port1
            IO1CLR = ~var1; // Once again Conforming (clearing all other bits)
            scan();
            delay(100); //delay
            if (flag == 0xff)
                break;
        } // end of for
        if (flag == 0xff)
            break;
    } // end of while
    for (i = 0; i < 16; i++) {
        if (scan_code[i] == res1) //equate the scan_code with res1
        {
            result = ASCII_CODE[i]; //same position value of ascii code
            break; //is assigned to result
        }
    }
} // end of get_key();
void scan(void) {
    unsigned long int t;
    temp2 = IO1PIN; // status of port1
    temp2 = temp2 & 0x000F0000; // Verifying column key
    if (temp2 != 0x000F0000) // Check for Key Press or Not
    {
        delay(1000); //delay(100)//give debounce delay check again
        temp2 = IO1PIN;
        temp2 = temp2 & 0x000F0000; //changed condition is same
        if (temp2 != 0x000F0000) // store the value in res1
        {
            flag = 0xff;
        }
    }
}
```

```
        res1 = temp2;
        t = (temp3 & 0x00F00000); //Verfying Row Write
        res1 = res1 | t; //final scan value is stored in res1
    } else {
        flag = 0x00;
    }
}
} // end of scan()

void display(void) {
    ptr = disp0;
    temp1 = 0x80; // Display starting address of first line
    lcd_com();

    while ( * ptr != '\0') {
        temp1 = * ptr;
        lcd_data();
        ptr++;
    }

    ptr = disp1;
    temp1 = 0xC0; // Display starting address of second line
    lcd_com();

    while ( * ptr != '\0') {
        temp1 = * ptr;
        lcd_data();
        ptr++;
    }
    temp1 = 0xC6; //display address for key value
    lcd_com();
    temp1 = result;
    lcd_data();
}

void lcd_init(void) {
    temp = 0x30;
    wr_cn();
    delay(3200);

    temp = 0x30;
    wr_cn();
    delay(3200);

    temp = 0x30;
    wr_cn();
    delay(3200);

    temp = 0x20;
    wr_cn();
    delay(3200);

    // load command for lcd function setting with lcd in 4 bit mode,
    // 2 line and 5x7 matrix display

    temp = 0x28;
    lcd_com();
    delay(3200);

    // load a command for display on, cursor on and blinking off
    temp1 = 0x0C;
    lcd_com();
}
```

```
    delay(800);

    // command for cursor increment after data dump
    temp1 = 0x06;
    lcd_com();
    delay(800);

    temp1 = 0x80;
    lcd_com();
    delay(800);
}

void lcd_data(void) {
    temp = temp1 & 0xf0;
    wr_dn();
    temp = temp1 & 0x0f;
    temp = temp << 4;
    wr_dn();
    delay(100);
}

void wr_dn(void) ////write data reg
{
    IO0CLR = 0x000000FC; // clear the port lines.
    IO0SET = temp; // Assign the value to the PORT lines
    IO0SET = 0x00000004; // set bit  RS = 1
    IO0SET = 0x00000008; // E=1
    delay(10);
    IO0CLR = 0x00000008;
}

void lcd_com(void) {
    temp = temp1 & 0xf0;
    wr_cn();
    temp = temp1 & 0x0f;
    temp = temp << 4;
    wr_cn();
    delay(500);
}

void wr_cn(void) //write command reg
{
    IO0CLR = 0x000000FC; // clear the port lines.
    IO0SET = temp; // Assign the value to the PORT lines
    IO0CLR = 0x00000004; // clear bit  RS = 0
    IO0SET = 0x00000008; // E=1
    delay(10);
    IO0CLR = 0x00000008;
}

void clr_disp(void) {
    // command to clear lcd display
    temp1 = 0x01;
    lcd_com();
    delay(500);
}

void delay(unsigned int r1) {
    for (r = 0; r < r1; r++);
}

void init_port() {
    IO0DIR = 0x000000FC; //configure o/p lines for lcd
    IO1DIR = 0xFFFF0FFFF;
}
}
```



K.S. INSTITUTE OF TECHNOLOGY, BANGALORE - 560109
DEPARTMENT OF COMPUTER SCIENCE AND ENGINEERING
TEACHING AND LEARNING

CONTENT BEYOND SYLLABUS REPORT

Academic Year	2024-2025(Even)
Name of the Faculty	Mrs. Vishva Kiran R C
Course Name /Code	Microcontrollers / BCS402
Semester/Section	IV / B
Activity Name	Analytical Demonstration of Peripheral Interfacing using ARM7 Microcontroller
Topic Covered	<ul style="list-style-type: none">• LCD Display• 7 Segment display• Stepper Motor• DC Motor• Relay• 4 x 4 Keypad
No. of Participants	68
Objectives/Goals	<ul style="list-style-type: none">• To bridge the gap between theoretical concepts and real-world embedded system applications.• To enhance students' understanding of ARM architecture, specifically the ARM7TDMI processor, through hands-on experiments.• To foster familiarity with peripheral interfacing, essential for embedded system design
ICT Used	<ul style="list-style-type: none">• ARM7 LPC2148 EVALUATION BOARD (ALS-SDA-ARM7-06)• Keil μVision v4.74• Flash magic v6.01
Appropriate Method/Instructional Materials/Exam Questions: <ul style="list-style-type: none">• A demonstration was given using ARM7 LPC2148 Evaluation board & peripheral devices• Hands-on with industry-standard tools like:<ul style="list-style-type: none">○ Keil μVision○ Flash Magic for flashing code○ JTAG for debugging	
Relevant CO's	CO1, CO2, CO3, CO5
Relevant PO's:	PO1, PO2, PO3, PO4, PO5, PO9, PO10, PO12
Significance of Results/Outcomes	<ul style="list-style-type: none">• Students developed a concrete understanding of how software instructions control hardware components.• Exposure to components like LCDs, 7-segment displays, and motors

	<p>deepened their knowledge of practical interfacing.</p> <ul style="list-style-type: none"> The session provided a stepping stone toward advanced embedded platforms like ARM7, ARM Cortex-M and real-time operating systems and motors.
Reflective Critique	<ul style="list-style-type: none"> The hands-on activity effectively translated theoretical learning into tangible skills. Students gained direct exposure to embedded system debugging and hardware control. The use of the ARM7 LPC2148 Evaluation Board enriched their learning experience by allowing experimentation with real-world microcontroller peripherals.

Proofs :
Sample copy of photos attached

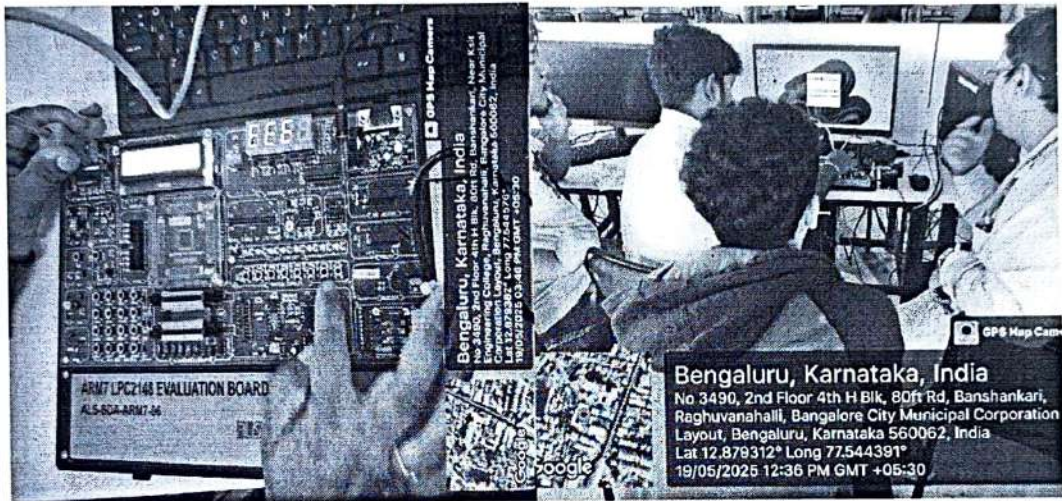

[Handwritten Signature]
Signature of Course In charge

[Handwritten Signature]
Signature of HOD
 Head of the Department
 Dept. of Computer Science & Engg
 K.S. Institute of Technology
 Bengaluru -560 109

1.1 MICROCONTROLLER FEATURES

Following are the features of 16 bit /32 bit LPC2148 Arm Microcontroller:

- PHILIPS LPC2148 is a 16-bit or 32-bit Microcontroller in a LQFP64-pin Package.
- 40 kB of on-chip static RAM and 512 kB of on-chip flash memory. 128-bit wide interface/accelerator enables high-speed 60 MHz operation.
- The LPC2148 provides 100000 erase/write cycles and 20 years of Data-retention.
- In-System Programming/In-Application Programming (ISP/IAP) via on-chip boot loader software. Single flash sector or full chip erase takes 400ms and Flash programming takes 1ms per 256-byte line.
- USB 2.0 Full speed compliant device controller with 2 kB of endpoint RAM. In addition, the LPC2148 provides 8 kB of on-chip RAM accessible to USB by DMA.
- Embedded ICE-RT and Embedded Trace Macro cell (ETM) interfaces offer real time debugging with on-chip Real Monitor software and high-speed real-time tracing of instruction execution.
- Two 10-bit ADCs provide a total of 14 analog inputs, with conversion times as low as 2.44 μ s per channel.
- Single 10-bit DAC provides variable analog output.
- Two 32-bit Timers/External event Counters (with four Capture and four Compare channels each), PWM unit (six outputs) and watchdog.
- Low power Real-Time Clock (RTC) with independent power and 32 kHz clock input.
- Multiple serial interfaces including two UARTs (16C550 equivalent), two Fast I2C-bus (400 kbit/s), SPI and SSP with buffering and variable data length capabilities.
- Vectored interrupt controller (VIC) with configurable priorities and vector addresses.
- Up to 45 numbers of 5 V tolerant fast general purpose I/O pins in a tiny LQFP64 package.
- Up to nine edge or level sensitive external interrupt pins available.
- 60 MHz maximum CPU clock available from programmable on-chip PLL with

settling time of 100 μ s.

- On-chip integrated oscillator operates with an external crystal in range from 1 MHz to 30 MHz and with an external oscillator up to 50 MHz.
- Power saving modes include Idle and Power-down.
- Individual power enable/disable of peripheral functions as well as peripheral clock scaling for additional power optimization.
- Processor wake-up from Power-down mode via external interrupt, USB, Brown-Out Detect (BOD) or Real-Time Clock (RTC).
- Single power supply chip with Power-On Reset (POR) and BOD circuits: CPU operating voltage range of 3.0 V to 3.6 V ($3.3 \text{ V} \pm 10 \%$) with 5 V tolerant I/O pads.

1.2 BOARD SPECIFICATIONS:

- LPC2148 16/32 BIT ARM7TDMI-S with 512K bytes Program Flash, 42K bytes RAM.
- 12MHz Crystal allows easy communication setup.
- One on board voltage regulator for generating 3.3V. Input to this will be from External +5V DC Power supply through a 9-pin DSUB connector.
- One RS232 interface circuits with 9 pin DSUB connector: this is used by the Boot loader program, to program LPC2148 Flash memory without external Programmer. Can also be used as a Serial port in applications
- Piggy Back module containing LPC2148 controller.
- Standard JTAG connector with ARM 2x10 pin layout for programming/debugging with ARM-JTAG.
- Standard 26-pin FRC connectors to connect to on-board interface or some of ALS standard External Interfaces.
- Reset push-button for resetting the controller.
- Onchip ADC interface circuit through a potentiometer.
- External interrupt0 interface using a key.
- External interrupt1 interface using a key with LED indication.

ARM7 Evaluation Board LPC2148 – Demonstration

- LCD 16x2 alphanumeric display.
- On-board eight push-button switches.
- 4x4 key matrix.
- Eight general purpose LED's: SMD 8 nos and THROUGH HOLE 8 nos.
- Four-digit multiplexed 7-segment display interface
- 8-bit DAC interface.
- Stepper motor interface with direction and speed control.
- DC motor interface with direction and speed control.
- Interface circuit for on board Buzzer and Relay.
- A number of software examples in 'C-language' to illustrate the functioning of the interfaces. The software examples are compiled using an evaluation version of KEIL4 'C' compiler for ARM.
- Compact elegant plastic enclosure.
- Serial RS232 cable is included.



INSTALLATION:

1.3 KEIL UVISION4 IDE INSTALLATION:

1. Installation of keilUvision4 as follows.
2. Go to Software folder in the CD and run Keil4 Arm.exe file.
3. Next
4. Click on the option "I agree to all the terms of..." and then give Next
5. Next
6. Give some name and the mail id and then Next
7. Click Finish to complete the installation.

1.4 PROJECT CREATION IN KEILUV4 IDE:

1. Create a project folder before creating NEW project.
2. Open Keil uVision4 IDE software by double clicking on "Keil Uvision4" icon.
3. Go to "Project" then to "New Project" and save it with a name in the Respective project folder, already you created.
4. Select the device as "NXP {founded by Philips}" In that "LPC2148" then press OK
5. and then press "YES" button to add "startup.s" file.
6. In startup file go to Configuration Wizard. In Configuration Wizard window disable PLL Setup and enable VPBDIV Setup.
7. Go to "File" In that "New" to open an editor window. Create your source file And use the header file "lpc21xx.h" in the source file and save the file. Colour syntax highlighting will be enabled once the file is saved with a Recognized extension such as ".C".
8. Right click on "Source Group 1" and select the option "Add Files to Group 'Source Group 1'" add the .C source file(s) to the group.
9. After adding the source file you can see the file in Project Window.
10. Then go to "Project" in that "Translate" to compile the File (s).

11. Go to "Project" in that "Build Target" for building all source files such as ".C", ".ASM", ".h", files, etc. This will create the .HEX file if no warnings & no Errors.

1.5 Some Settings to be done in KEILUV4 for Executing C programs:

1. In Project Window Right click "TARGET1" and select "options for target 'TARGET1'"
 - Then go to option "Target" in that
 1. Xtal 12.0MHz
 2. Select "Use MicroLIB".
 3. Select IROM1 (starting 0x0 size 0x80000).
 4. Select IRAM1 (starting 0x40000000 size 0x8000).
 - Then go to option "Output"
 1. Select "Create Hex file".
 - Then go to option "Linker"
 1. Select "Use Memory Layout for Target Dialog".

1.6 FLASH MAGIC VERSION 6.01.2547:

Installation of Flash Magic as follows.

1. Go to Software folder in the CD and run FlashMagic.exe file.
2. Next
3. Click on the option "I Accept the Agreement" and then give Next
4. Then it asks the Destination location, Click Next.
5. Further Select start menu folder, Click Next.
6. Select "Create a desktop icon" then Next
7. It asks "Ready to Install" Click INSTALL.
8. Click Finish to complete the installation.

1.7 ISP PROGRAMMING:

FLASH MAGIC software can be used to download the HEX files to the Flash memory of controller.

How to Download?

Connect the serial cross cable from 9-pin DSUB Female connector (DB2) to the PC COM port. Switch on both buttons of SW11. SW11(1-RTS), SW11(2-DTR). Connect DC +5V Power, through the 9-pin DSUB FEMALE connector (DB1) applied from an external source. Switch ON the power.

1.8 Some Settings in FLASH MAGIC:

Step1. Communications:

1. Device : LPC2148
2. Com Port : COM1
3. Baud Rate : 9600
4. Interface : None(ISP)
5. Oscillator : 12MHz

Step2. ERASE:

1. Select "Erase Blocks Used By Hex File".

Step3. Hex file:

1. Browse and select the Hex file which you want to Download.

Step4. Start:

1. Click Start to download the hex file to the controller.

After downloading the code the program starts executing in the hardware, then remove the ISP jumper JP4.

Note: In FLASH MAGIC Go to Options and then in Advanced Options

- Select High Speed Communications (115200) in Communications tab.
- Select Use DTR & RTS to control RST & ISP Pin and Keep RTS asserted while COM Port open.

For all the programs make sure that the corresponding settings have to be made:

1. Both Switches of SW11 should be in ON position for ISP programming.
2. Short JP7 for ISP programming.
3. Short JP5 to connect +3.3v into the circuit.
4. Short JP4 to connect +5v to Interface Board.
5. Connect the 26 core FRC cable CN7 to CN8 to connect to External interfaces.
6. Connect CN7 for External NIFC's.

DEMONSTRATION 1: LCD DISPLAY

//////// "LCD DISPLAY" To display the predefined data //////////

```
#include<lpc214x.h>
#include<stdio.h>

//Function prototypes
void lcd_init(void);
void wr_cn(void);
void clr_disp(void);
void delay(unsigned int);
void lcd_com(void);
void wr_dn(void);
void lcd_data(void);
```

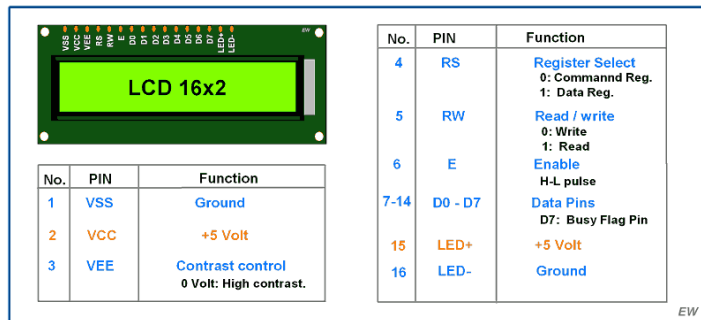

```
unsigned char temp1;
unsigned long int temp,r=0;
unsigned char *ptr,disp[] = "KSIT CSE Dept",displ[] = "BENGALURU-109";
```

```
int main()
{
    IOODIR = 0x000000FC;           //configure o/p lines for lcd
    IOOPIN = 0X00000000;

    delay(3200);                   //delay
    lcd_init();                    //lcd intialisation
    delay(3200);                   //delay
    clr_disp();                    //clear display
    delay(3200);                   //delay

    //.....LCD DISPLAY TEST.....//
    temp1 = 0x80;//Display starting address of first line 1st pos
    lcd_com();

    ptr = disp;
    while(*ptr!='\0')
    {
        temp1 = *ptr;
        lcd_data();
        ptr ++;
    }

    temp1 = 0xC0;// Display starting address of second line 4th pos
    lcd_com();

    ptr = displ;
    while(*ptr!='\0')
    {
        temp1 = *ptr;
        lcd_data();
        ptr ++;
    }
    while(1);
} //end of main()

// lcd initialisation routine.
void lcd_init(void)
{
    temp = 0x30;
    wr_cn();
    delay(3200);
```

```
temp = 0x30;
wr_cn();
delay(3200);

temp = 0x30;
wr_cn();
delay(3200);

temp = 0x20;    // change to 4 bit mode from default 8 bit mode
wr_cn();
delay(3200);

// load command for lcd function setting with lcd in 4 bit mode,
// 2 line and 5x7 matrix display

temp = 0x28;
lcd_com();
delay(3200);

// load a command for display on, cursor on and blinking off
temp1 = 0x0C;
lcd_com();
delay(800);

// command for cursor increment after data dump
temp1 = 0x06;
lcd_com();
delay(800);

temp1 = 0x80; // set the cursor to beginning of line 1
lcd_com();
delay(800);
}

void lcd_com(void)
{
    temp = temp1 & 0xf0;
    wr_cn();
    temp = temp1 & 0x0f;
    temp = temp << 4;
    wr_cn();
    delay(500);
}

// command nibble o/p routine
void wr_cn(void) //write command reg
{
    IOOCLR = 0x000000FC; // clear the port lines.
    IOOSET = temp; // Assign the value to the PORT lines
    IOOCLR = 0x00000004; // clear bit RS = 0
    IOOSET = 0x00000008; // E=1
    delay(10);
    IOOCLR = 0x00000008;
}

// data nibble o/p routine
void wr_dn(void) //write data reg
{
    IOOCLR = 0x000000FC; // clear the port lines.
    IOOSET = temp; // Assign the value to the PORT lines
    IOOSET = 0x00000004; // set bit RS = 1
}
```

```

        IOOSET = 0x00000008;          // E=1
        delay(10);
        IOOCLR = 0x00000008;
    }

// data o/p routine which also outputs high nibble first
// and lower nibble next
void lcd_data(void)
{
    temp = temp1 & 0xf0;
    temp = temp ;//<< 6;
    wr_dn();
    temp= temp1 & 0x0f;
    temp= temp << 4;
    wr_dn();
    delay(100);
}

void clr_disp(void)
{
// command to clear lcd display
    temp1 = 0x01;
    lcd_com();
    delay(500);
}

void delay(unsigned int r1)
{
    for(r=0;r<r1;r++);
}
    
```

DEMONSTRATION 2: 7 segment displays

```
#include <LPC21xx.h>
```

```

/*//////////////////////////////////DISPLAY ARE CONNECTED IN COMMON CATHODE
MODE//////////////////////////////////
    Port0 Connected to data lines of all 7 segement displays
    a = P0.10
    b = P0.11
    c = P0.12
    d = P0.13
    e = P0.18
    f = P0.19
    g = P0.20
    dot = P0.21

    Select lines for four 7 Segments
    DIS1 P0.28
    DIS2 P0.29
    DIS3 P0.30
    DIS4 P0.31
*/
    
```

7-Segment Display

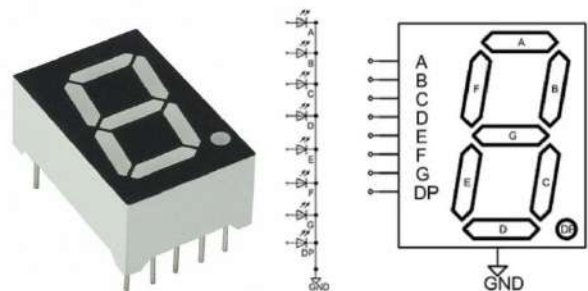

```

unsigned int delay, count=0, Switchcount=0;
unsigned int Disp[16]={0x003F0000, 0x00060000, 0x005B0000, 0x004F0000,
0x00660000,0x006D0000, 0x007D0000, 0x00070000, 0x007F0000, 0x006F0000,
0x00770000,0x007C0000, 0x00390000, 0x005E0000, 0x00790000, 0x00710000 };

#define SELDISP1 0x10000000 //P0.28
#define SELDISP2 0x20000000 //P0.29
#define SELDISP3 0x40000000 //P0.30
    
```

```
#define SELDISP4 0x80000000 //P0.31
#define ALLDISP 0xF0000000 //Select all display
#define DATAPORT 0x00FF0000
//P0.16 to P0.23 : Data lines connected to drive Seven Segments

int main (void)
{
    PINSEL0 = 0x00000000;
    PINSEL1 = 0x00000000;
    IOODIR = 0xF0FF0000;
    IO1DIR = 0x01000000;

    while(1)
    {
        //Display values on Seven Segment
        IO0SET |= ALLDISP;
        IO0CLR = 0x00FF0000;

        for(delay=0;delay<100;delay++)
            IO0SET = Disp[Switchcount];
        // display the values 0 to F one after the other
        for(delay=0;delay<1000000;delay++)
            {}

        Switchcount++;
        if(Switchcount == 16) // after F go back to 0
        {
            Switchcount = 0;
        }
    }
}
```

DEMONSTRATION 3: STEPPER Motor

```
#include <LPC21xx.H>

void clock_wise(void);
void anti_clock_wise(void);

unsigned long int var1, var2;
unsigned int i = 0, j = 0, k = 0;

int main(void) {
    PINSEL0 = 0x00FFFFFF; //P0.12 to P0.15 GPIO
    IOODIR |= 0x0000F000; //P0.12 to P0.15 output

    while (1) {
        for (j = 0; j < 50; j++) // 20 times in Clock wise Rotation
            clock_wise();

        for (k = 0; k < 65000; k++); // Delay to show anti_clock Rotation

        for (j = 0; j < 50; j++) // 20 times in Anti Clock wise Rotation
            anti_clock_wise();

        for (k = 0; k < 65000; k++); // Delay to show clock Rotation

    } // End of while(1)

} // End of main

void clock_wise(void) {
```

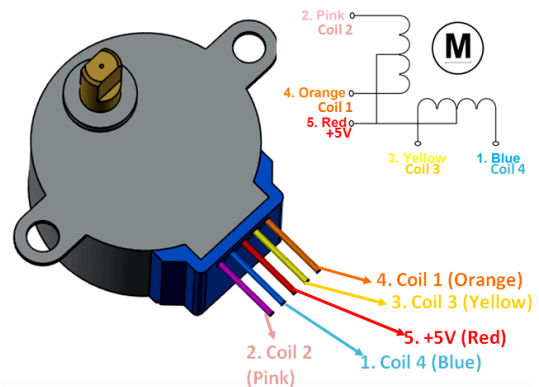

```
var1 = 0x00000800; //For Clockwise
for (i = 0; i <= 3; i++) // for A B C D Stepping
{
    var1 = var1 << 1; //For Clockwise

    IO0PIN = var1;

    for (k = 0; k < 3000; k++); //for step speed variation
}
}

void anti_clock_wise(void) {
    var1 = 0x00010000; //For Anticlockwise
    for (i = 0; i <= 3; i++) // for A B C D Stepping
    {
        var1 = var1 >> 1; //For Anticlockwise

        IO0PIN = var1;
        for (k = 0; k < 3000; k++); //for step speed variation

    }
}
```

DEMONSTRATION 4: DC Motor

```
#include<lpc214x.h>

void clock_wise(void);
void anti_clock_wise(void);
unsigned int j = 0;

int main() {
    IO0DIR = 0x00000900;
    IO0SET = 0x00000100; //P0.8 should always high.

    while (1) {
        clock_wise();
        for (j = 0; j < 400000; j++); //delay
        anti_clock_wise();
        for (j = 0; j < 400000; j++); //delay
    } //End of while(1)
} //End of Main

void clock_wise(void) {
    IO0CLR = 0x00000900; //stop motor and also turn off relay
    for (j = 0; j < 10000; j++); //small delay to allow motor to turn off
    IO0SET = 0x00000900; //Selecting the P0.11 line for clockwise and turn
on motor
}

void anti_clock_wise(void) {
    IO0CLR = 0x00000900; //stop motor and also turn off relay
    for (j = 0; j < 10000; j++); //small delay to allow motor to turn off
    IO0SET = 0x00000100; //not selecting the P0.11 line for Anti clockwise
}
```



DEMONSTRATION 5: Relay Switch

```
#include <LPC21xx.h>

unsigned int i;

int main ()
{
    IOODIR = 0x00000400;           //Set P0.10 as output
    IOOSET = 0x00000400;         //P0.10 is set to a HI

    while(1)
    {
        for(i=0;i<1000000;i++)
        {}
        IOOSET = 0x00000400;       //RLY ON
        for(i=0;i<1000000;i++)
        {}
        IOOCLR = 0x00000400;      //RLY OFF
    }
}
```

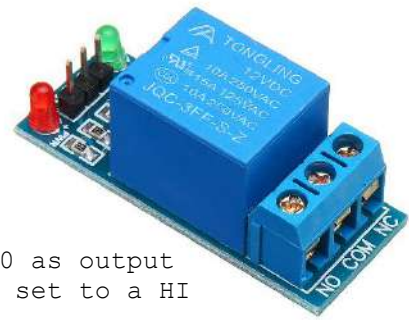

DEMONSTRATION 6: 4 x 4 key board

```
#include<lpc21xx.h>
#include<stdio.h>
void lcd_init(void);
void clr_disp(void);
void lcd_com(void);
void lcd_data(void);
void wr_cn(void);
void wr_dn(void);
void scan(void);
void get_key(void);
void display(void);
void delay(unsigned int);
void init_port(void);
unsigned long int scan_code[16] = { 0x00EE0000, 0x00ED0000, 0x00EB0000,
0x00E70000, 0x00DE0000, 0x00DD0000, 0x00DB0000, 0x00D70000,
0x00BE0000, 0x00BD0000, 0x00BB0000, 0x00B70000, 0x007E0000,
0x007D0000, 0x007B0000, 0x00770000};

unsigned char ASCII_CODE[16] = { '0', '1', '2', '3', '4', '5', '6',
'7', '8', '9', 'A', 'B', 'C', 'D', 'E', 'F'};

unsigned char row, col;
unsigned char temp, flag, i, result, temp1;
unsigned int r, r1;
unsigned long int
var, var1, var2, res1, temp2, temp3, temp4;
unsigned char * ptr, disp[] = "4X4 KEYPAD";
unsigned char disp0[] = "KEYPAD TESTING";
unsigned char disp1[] = "KEY = ";

int main() {
    // __ARMLIB_enableIRQ();
    init_port(); //port intialisation
    delay(3200); //delay
    lcd_init(); //lcd intialisation
    delay(3200); //delay
    clr_disp(); //clear display
    delay(500); //delay
    //.....LCD DISPLAY TEST.....//
    ptr = disp;
```



4x4 Matrix Keypad

```
temp1 = 0x81; // Display starting address
lcd_com();
delay(800);
while ( * ptr != '\0') {
    temp1 = * ptr;
    lcd_data();
    ptr++;
}
//.....KEYPAD Working.....//
while (1) {
    get_key();
    display();
}
} //end of main()
void get_key(void) //get the key from the keyboard
{
    unsigned int i;
    flag = 0x00;
    IO1PIN = 0x000f0000;
    while (1) {
        for (row = 0X00; row < 0X04; row++) //Writing one for col's
        {
            if (row == 0X00) {
                temp3 = 0x00700000;
            } else if (row == 0X01) {
                temp3 = 0x00B00000;
            } else if (row == 0X02) {
                temp3 = 0x00D00000;
            } else if (row == 0X03) {
                temp3 = 0x00E00000;
            }
            var1 = temp3;
            IO1PIN = var1; // each time var1 value is put to port1
            IO1CLR = ~var1; // Once again Conforming (clearing all other bits)
            scan();
            delay(100); //delay
            if (flag == 0xff)
                break;
        } // end of for
        if (flag == 0xff)
            break;
    } // end of while
    for (i = 0; i < 16; i++) {
        if (scan_code[i] == res1) //equate the scan_code with res1
        {
            result = ASCII_CODE[i]; //same position value of ascii code
            break; //is assigned to result
        }
    }
} // end of get_key();
void scan(void) {
    unsigned long int t;
    temp2 = IO1PIN; // status of port1
    temp2 = temp2 & 0x000F0000; // Verifying column key
    if (temp2 != 0x000F0000) // Check for Key Press or Not
    {
        delay(1000); //delay(100)//give debounce delay check again
        temp2 = IO1PIN;
        temp2 = temp2 & 0x000F0000; //changed condition is same
        if (temp2 != 0x000F0000) // store the value in res1
        {
            flag = 0xff;
        }
    }
}
```

```
        res1 = temp2;
        t = (temp3 & 0x00F00000); //Verfying Row Write
        res1 = res1 | t; //final scan value is stored in res1
    } else {
        flag = 0x00;
    }
}
} // end of scan()

void display(void) {
    ptr = disp0;
    temp1 = 0x80; // Display starting address of first line
    lcd_com();

    while ( * ptr != '\0') {
        temp1 = * ptr;
        lcd_data();
        ptr++;
    }

    ptr = disp1;
    temp1 = 0xC0; // Display starting address of second line
    lcd_com();

    while ( * ptr != '\0') {
        temp1 = * ptr;
        lcd_data();
        ptr++;
    }
    temp1 = 0xC6; //display address for key value
    lcd_com();
    temp1 = result;
    lcd_data();
}

void lcd_init(void) {
    temp = 0x30;
    wr_cn();
    delay(3200);

    temp = 0x30;
    wr_cn();
    delay(3200);

    temp = 0x30;
    wr_cn();
    delay(3200);

    temp = 0x20;
    wr_cn();
    delay(3200);

    // load command for lcd function setting with lcd in 4 bit mode,
    // 2 line and 5x7 matrix display

    temp = 0x28;
    lcd_com();
    delay(3200);

    // load a command for display on, cursor on and blinking off
    temp1 = 0x0C;
    lcd_com();
}
```

```
    delay(800);

    // command for cursor increment after data dump
    temp1 = 0x06;
    lcd_com();
    delay(800);

    temp1 = 0x80;
    lcd_com();
    delay(800);
}

void lcd_data(void) {
    temp = temp1 & 0xf0;
    wr_dn();
    temp = temp1 & 0x0f;
    temp = temp << 4;
    wr_dn();
    delay(100);
}

void wr_dn(void) ////write data reg
{
    IO0CLR = 0x000000FC; // clear the port lines.
    IO0SET = temp; // Assign the value to the PORT lines
    IO0SET = 0x00000004; // set bit RS = 1
    IO0SET = 0x00000008; // E=1
    delay(10);
    IO0CLR = 0x00000008;
}

void lcd_com(void) {
    temp = temp1 & 0xf0;
    wr_cn();
    temp = temp1 & 0x0f;
    temp = temp << 4;
    wr_cn();
    delay(500);
}

void wr_cn(void) //write command reg
{
    IO0CLR = 0x000000FC; // clear the port lines.
    IO0SET = temp; // Assign the value to the PORT lines
    IO0CLR = 0x00000004; // clear bit RS = 0
    IO0SET = 0x00000008; // E=1
    delay(10);
    IO0CLR = 0x00000008;
}

void clr_disp(void) {
    // command to clear lcd display
    temp1 = 0x01;
    lcd_com();
    delay(500);
}

void delay(unsigned int r1) {
    for (r = 0; r < r1; r++);
}

void init_port() {
    IO0DIR = 0x000000FC; //configure o/p lines for lcd
    IO1DIR = 0xFFFF0FFFF;
}
}
```



K.S. INSTITUTE OF TECHNOLOGY, BANGALORE – 560109

DEPARTMENT OF COMPUTER SCIENCE & ENGINEERING

TEACHING AND LEARNING

CONTENT BEYOND SYLLABUS

Academic Year	2024-25 (EVEN)
Name of the Faculty	Kodur Srividya
Course Name /Code	Microcontrollers (BCS402)
Semester/Section	IV / C
Activity Name	Demonstration of Programs on ARM Kit: 1. "LCD DISPLAY" To display the predefined data. 2. "7 Segment display with Counter"
Date	10-04-2025
Topic Covered	Demonstration of the following extra programs which are not covered in the syllabus of Laboratory: 1. "LCD DISPLAY" To display the predefined data. 2. "7 Segment display with Counter"
No. of Participants	66/66
Objectives/Goals	<ul style="list-style-type: none">• Demonstrate on 4x4 keyboard, LCD display, Counters, 7 Segment display, GPIO (General Purpose Input/Output) pin control for interfacing with sensors, DC motors, stepper motors and other components which are there on the ARM Kit.• Explore IoT (Internet of Things) applications using Microcontrollers.
ICT Used	Demonstration on Kit (Experiment)
Appropriate Method/Instructional materials/Exam Questions Demonstration (Experiment) on ARM Kit.	
Relevant CO's	CO1, CO2, CO3, C04, CO5
Relevant PO's	PO5, PO9, PO10, PO12
Significance of Results/Outcomes	Students were able to understand the concepts of ARM Microcontroller Kit and its applications.
Reflective Critique	It aims students to sharpen their skill sets and prepare well for their future career.

Sample Photographs of Demonstration on ARM Kit:

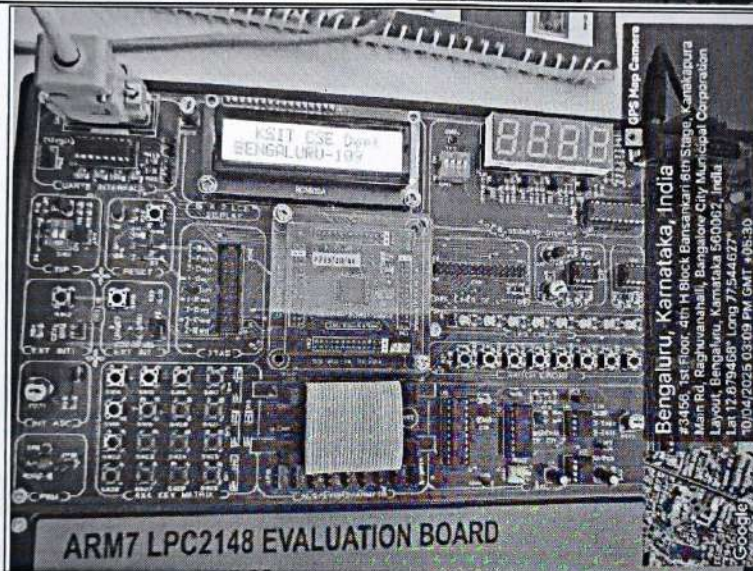

Proofs:

<https://drive.google.com/drive/folders/1zPR-JtBKsPa-kdu15InTyllwMP9qSjiB?usp=sharing>

A Sample of Student Record Attached.

PROGRAMS CONDUCTED:

ACTIVITY NAME:

Demonstration on ARM Kit:

- "LCD DISPLAY" To display the predefined data.
- "7 Segment display with Counter".

// lcd initialisation routine.

```
void lcd_init(void)
{
    temp = 0x30;
    wr_cn();
    delay(3200);
    temp = 0x30;
    wr_cn();
    delay(3200);
    temp = 0x30;
    wr_cn();
    delay(3200);
    temp = 0x20; // change to 4 bit mode from default 8 bit mode
    wr_cn();
    delay(3200);
```

**// load command for lcd function setting with lcd in 4 bit mode,
// 2 line and 5x7 matrix display**

```
temp = 0x28;
lcd_com();
delay(3200);
```

// load a command for display on, cursor on and blinking off

```
temp1 = 0x0C;
lcd_com();
delay(800);
```

// command for cursor increment after data dump

```
temp1 = 0x06;
lcd_com();
delay(800);
temp1 = 0x80; // set the cursor to beginning of line 1
lcd_com();
delay(800);
```

```
}
void lcd_com(void)
```

```
{
    temp = temp1 & 0xf0;
    wr_cn();
    temp = temp1 & 0x0f;
    temp = temp << 4;
    wr_cn();
    delay(500);
}
```

// command nibble o/p routine

```
void wr_cn(void) //write command reg
```

```
{
    IO0CLR = 0x000000FC; // clear the port lines.
    IO0SET = temp; // Assign the value to the PORT lines
    IO0CLR = 0x00000004; // clear bit RS = 0
    IO0SET = 0x00000008; // E=1
    delay(10);
    IO0CLR = 0x00000008;
```

```
}
// data nibble o/p routine
```

```
void wr_dn(void) //write data reg
```

```
{
```

PROGRAM 1: "LCD DISPLAY" To display the predefined data.

///// "LCD DISPLAY" To display the predefined data/////

```
#include<lpc214x.h>
#include<stdio.h>
//Function prototypes
void lcd_init(void);
void wr_cn(void);
void clr_disp(void);
void delay(unsigned int);
void lcd_com(void);
void wr_dn(void);
void lcd_data(void);
unsigned char temp1;
unsigned long int temp,r=0;
unsigned char *ptr,disp[] = "TMI,R&D SECTION,",disp1[] = "KSIT CSE Dept BENGALURU-109";
int main()
{
    IOODIR = 0x000000FC;    //configure o/p lines for lcd
    IOOPIN = 0X00000000;
    delay(3200);          //delay
    lcd_init();           //lcd intialisation
    delay(3200);          //delay
    clr_disp();           //clear display
    delay(3200);          //delay
//.....LCD DISPLAY TEST.....//
    temp1 = 0x80;         //Display starting address of first line 1 th pos
    lcd_com();
    ptr = disp;
    while(*ptr!='\0')
    {
        temp1 = *ptr;
        lcd_data();
        ptr ++;
    }
    temp1 = 0xC0;         // Display starting address of second line 4 th pos
    lcd_com();
    ptr = disp1;
    while(*ptr!='\0')
    {
        temp1 = *ptr;
        lcd_data();
        ptr ++;
    }
    while(1);

} //end of main()
```

PROGRAM 2: "7 Segment display with Counter".

```
#include <LPC21xx.h>
/*/////////////////DISPLAY ARE CONNECTED IN COMMON CATHODE MODE/////////////////
Port0 Connected to data lines of all 7 segment displays
  a
  ----
 f| g |b
 |----|
 e| |c
 ---- . dot
  d
 a = P0.10
 b = P0.11
 c = P0.12
 d = P0.13
 e = P0.18
 f = P0.19
 g = P0.20
 dot = P0.21
Select lines for four 7 Segments
DIS1 P0.28
DIS2 P0.29
DIS3 P0.30
DIS4 P0.31
*/
unsigned int delay, count=0, Switchcount=0;
unsigned int Disp[16]={0x003F0000, 0x00060000, 0x005B0000, 0x004F0000,
0x00660000,0x006D0000,0x007D0000, 0x00070000, 0x007F0000, 0x006F0000,
0x00770000,0x007C0000, 0x00390000, 0x005E0000, 0x00790000, 0x00710000 };
#define SELDISP1 0x10000000 //P0.28
#define SELDISP2 0x20000000 //P0.29
#define SELDISP3 0x40000000 //P0.30
#define SELDISP4 0x80000000 //P0.31
#define ALLDISP 0xF0000000 //Select all display
#define DATAPORT 0x00FF0000 //P0.16 to P0.23 : Data lines connected to drive Seven
Segments
int main (void)
{
    PINSEL0 = 0x00000000;
    PINSEL1 = 0x00000000;
    IO0DIR = 0xF0FF0000;
    IO1DIR = 0x01000000;
    while(1)
    {
        //Display values on Seven Segment
        IO0SET |= ALLDISP;
        IO0CLR = 0x00FF0000;
        for(delay=0;delay<100;delay++)
            IO0SET = Disp[Switchcount]; // display the values 0 to F one
        after the other
        for(delay=0;delay<1000000;delay++)
        {
            Switchcount++;
        }
    }
}
```

```

IOOCLR = 0x000000FC;    // clear the port lines.
IOOSET = temp;          // Assign the value to the PORT lines
IOOSET = 0x00000004;    // set bit RS = 1
IOOSET = 0x00000008;    // E=1
delay(10);
IOOCLR = 0x00000008;
}
// data o/p routine which also outputs high nibble first
// and lower nibble next
void lcd_data(void)
{
temp = temp1 & 0xf0;
temp = temp >> 4;
wr_dn();
temp = temp1 & 0x0f;
temp = temp << 4;
wr_dn();
delay(100);
}
void clr_disp(void)
{
// command to clear lcd display
temp1 = 0x01;
lcd_com();
delay(500);
}
void delay(unsigned int r1)
{
for(r=0;r<r1;r++);
}

```

OUTPUT:

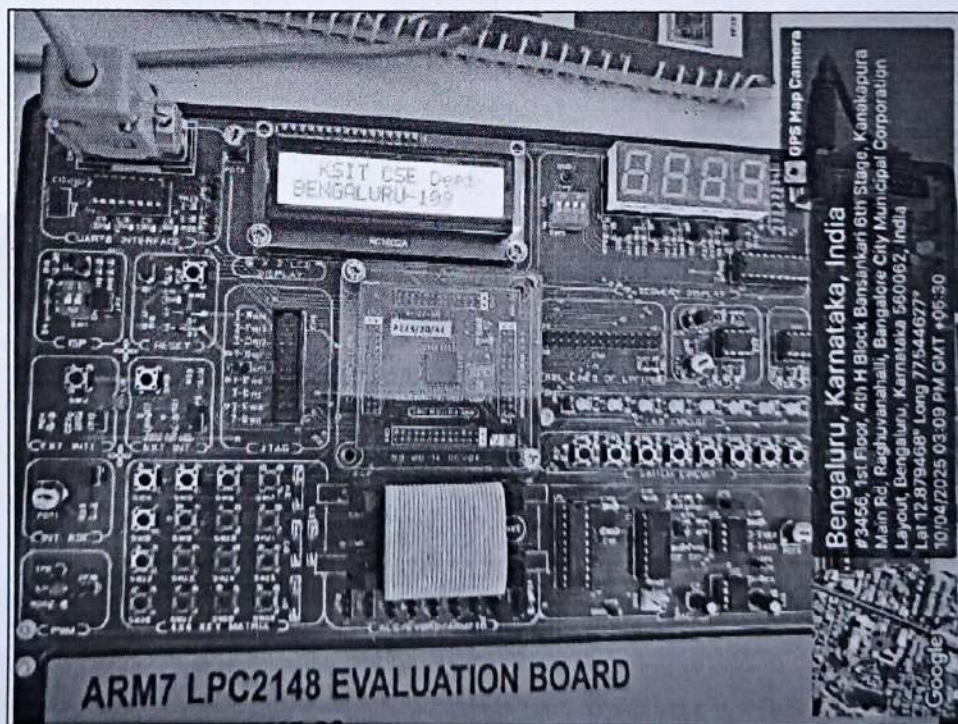

```

if(Switchcount == 16)                // after F go back to 0
{
    Switchcount = 0;
}
}

```

OUTPUT:

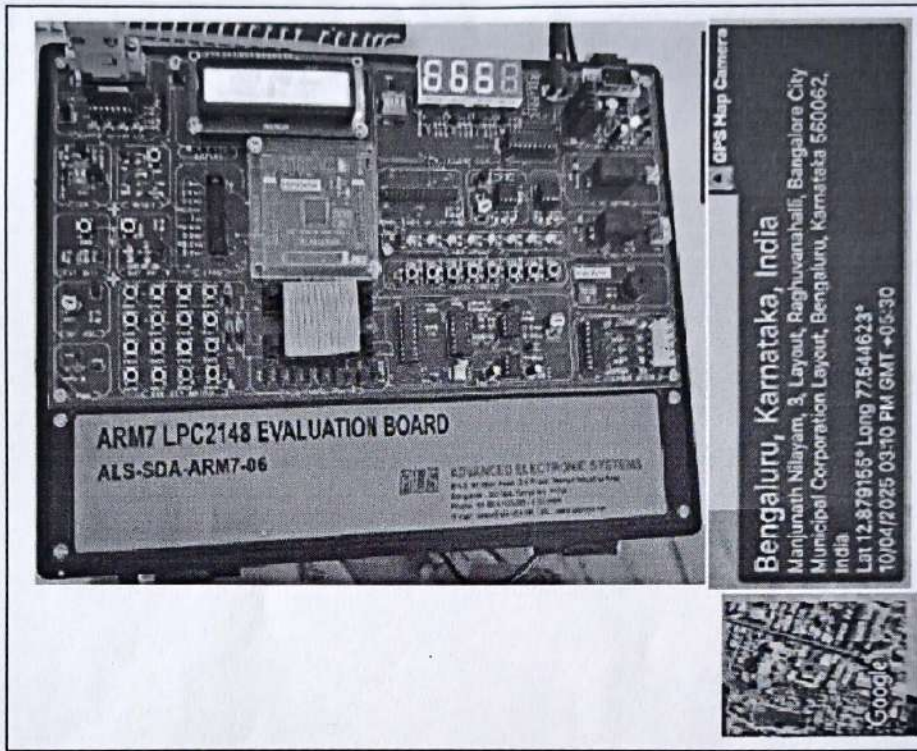

Conclusion/Outcomes:

- Extra programs were demonstrated which are not covered in the syllabus of Laboratory.
- Students could understand the concepts and also the usage of 4x4 keyboard, LCD display, Counters, 7 Segment display, GPIO (General Purpose Input/Output) pin control for interfacing with sensors, DC motors, stepper motors and other components which are there on the ARM Kit.
- Finally, Students were able to understand the concepts of ARM Microcontroller Kit and its applications.

K. Saindya

Signature of the Course In-charge

M. Narayana
Signature of HOD-CSE

Head of the Department
Dept. of Computer Science & Engg
K.S. Institute of Technology
Bengaluru -560 109



K.S. INSTITUTE OF TECHNOLOGY, BANGALORE - 560109
DEPARTMENT OF COMPUTER SCIENCE AND ENGINEERING
TEACHING AND LEARNING

ACADEMIC YEAR 2024-25 EVEN SEMESTER

CONTENT BEYOND SYLLABUS REPORT

Academic Year	2024 -25 EVEN SEMESTER
Name of the Faculty	Mr.T SOMASEKHAR, DR SOUBHAGYA LAKSHMI & MRS.SUMA RAJESH
Course Name /Code	DBMS / BCS403
Semester/Section	4TH SEMESTER/A/B/C
Activity Name	MINI-PROJECT EXHIBITION -2025
Topic Covered	CSE 4th-semester B.E. mini-project topics includes web development, database management, software engineering e.t.c
No. of Participants	28 (Final Short Listed project Batches from A/B/C Sections)
Objectives/Goals	The goal of a mini-project exhibition for CSE 4th-sem B.E. students is to apply theoretical concepts to real-world problems, develop practical skills, and showcase projects to potential employers.
ICT Used	ICT used in mini-projects includes software development, web development, data analysis, AI, IoT, and digital media.
Appropriate Method/Instructional Materials/Exam Questions:	
Mini-Project Exhibition	
Relevant CO's	CO1,CO2,CO3,CO4,CO5
Relevant PO's:	PO1,PO2,PO3,PO5,PO9,P10
Significance of Results/Outcomes	Mini-project exhibition for CSE 4th-sem B.E. students applied theoretical concepts to real-world problems;
Reflective Critique	Students Gained more Knowledge on database concepts and Web development
Proofs :	
Document attached below.	
Sample copy of the certificate attached: Photo attached in the Document.	



KS INSTITUTE OF TECHNOLOGY
DEPARTMENT OF COMPUTER SCIENCE & ENGINEERING
Mini Project Exhibition- 2024-25 (Even Semester)
"Database Management Systems"

Semester:	4 th Semester
Event Type:	Contest
Event Name:	Mini-Project Exhibition -2025
Date/Duration:	9 th June 2025/ 1 day
Associated Professional Bodies:	Institutions Innovative Council(IIC)
No. of Students:	37
Chief Guest:	Mr Girish K R, Sr.Project Engineer Intel Corporation, Bangalore
Online link/Offline:	Offline

Event Objectives:

DBMS project exhibition showcases the practical application of database management system concepts. Students have worked on designing, developing, and analyzing databases, demonstrating their technical literacy and potential.

Applying Database Concepts: To understand the practical applicability of DBMS concepts, including designing relational databases, analyzing table design, and working with existing database systems.

Industry Readiness: To equip students with the technical skills and knowledge required to tackle complex database challenges in the industry.

Advanced Database Skills: To gain hands-on experience with advanced database concepts.

Event description with pictures:

Description of the Event: On June 9, 2025, a mini-project exhibition was held for 4th-semester students (sections A, B, and C). The event commenced with an inauguration ceremony, featuring esteemed jury members:

- Mr. Girish K.R, Senior Project Engineer, Intel Corporation
- Mrs. Ramya Girish
- Presided by Dr. Rekha B Venkatapur, Professor and HOD-CSE

The exhibition showcased Database Management Systems mini-projects, coordinated by:

- Prof. Somasekhar T, Associate Professor
- Dr. Soubhagya Lakshmi, Associate Professor
- Mrs. Suma Rajesh, Assistant Professor
- Mrs. Beena K, Assistant Professor

Fifty students from the 4th semester participated in the event, demonstrating their DBMS projects.

Event Photos (Geo Tagged) :





Monday, June 09 2025, 09:48:23
VGHW+G4J, Kanakapura Main Rd,
Raghuvanahalli, Bangalore City Municipal
Corporation Layout, Bengaluru, Karnataka
560062, India
12° 52' 43" N, 77° 32' 42" E 820m
25.1°C 18.0Km/h 79%

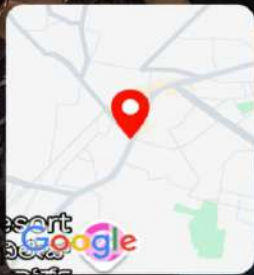

GPS Map Camera

Bengaluru, Karnataka, India
Vghw+g4j, Kanakapura Main Rd,
Bangalore City Municipal Corporation Layout,
Bengaluru, Karnataka 560062, India
Lat 12.878789° Long 77.545216°
09/06/2025 10:13 AM GMT +05:30

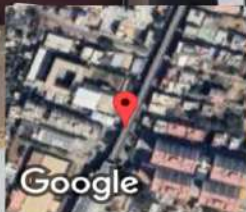



 GPS Map Camera

Bengaluru, Karnataka, India
303, Layout, Raghuvanahalli, Bangalore City Municipal Corporation Layout, Bengaluru,
Karnataka 560062, India
Lat 12.878828° Long 77.545145°
09/06/2025 09:59 AM GMT +05:30



 GPS Map Camera

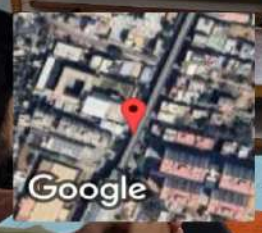

Bengaluru, Karnataka, India
Vghw+g4j, Kanakapura Main Rd, Raghuvanahalli,
Bangalore City Municipal Corporation Layout,
Bengaluru, Karnataka 560062, India
Lat 12.878818° Long 77.545202°
09/06/2025 12:05 PM GMT +05:30



Bengaluru, Karnataka, India
Vghw+g4j, Kanakapura Main Rd, Raghuvanahalli,
Bangalore City Municipal Corporation Layout,
Bengaluru, Karnataka 560062, India
Lat 12.878831° Long 77.545208°
09/06/2025 12:06 PM GMT +05:30



Bengaluru, Karnataka, India
Vghw+g4j, Kanakapura Main Rd, Raghuvanahalli,
Bangalore City Municipal Corporation Layout,
Bengaluru, Karnataka 560062, India
Lat 12.87883° Long 77.545208°
09/06/2025 12:06 PM GMT +05:30



Winners list:

USN	Name of the student	Title of the project
1KS23CS144	SHAMA SHIVARAJ SHETTY	Pharmacy Management System
1KS23CS145	SHAMITH GOWDA A G	
1KS23CS146	SHASHANK GOWDA U	

Runner-up list 1:

USN	Name of the student	Title of the project
1KS23CS114	Priyadharshini E P	Crime Management
1KS23CS109	Prajwal N	
1KS23CS090	Namratha M.H	
1KS23CS100	Srikanth Kashyap	

Runner-up list 2:

USN	Name of the student	Title of the project
1KS23CS123	RAZIYA KHAN	Online Shopping Management
1KS23CS121	RASHMI SONI	
1KS23CS124	REEMA J	
1KS23CS125	RITIKA SINGH	

Runner-up list 3:

USN	Name of the student	Title of the project
1KS23CS120	RAJATH KUMAR	Automated voting System
1KS23CS097	Nishanth C.P	
1KS23CS102	Pavan Gowda S	

Outcomes / Benefits:

The students got the opportunity to demonstrate their projects and got inputs from the judge to enhance their skills and improvise their projects.

Student Feed back

Time stamp	NAME	USN	1. How was the project experience	2. How relevant was the project to the course?	3. How would you rate the difficulty level?	4. How useful was the Project in Understanding DBMS Concept?	5. How would you rate the project Duration?	6. How was the Guidance Provided?	7. Did the project enhance your problem solving skill?	8. How would you rate the project workload?	9. How would you rate the project topic?	10. Would you suggest this project to others?
09/06/2025 13:14:20	Rajath Kumar Y G	1KS23 CS120	Excellent	Very Relevant	Just Right	Very Useful	Just Right	Very Helpful	Strongly Agree	Manageable	Very Interesting	Definitely
09/06/2025 15:52:13	PUNYA SHREE B	1KS23 CS117	Excellent	Very Relevant	Challenging	Very Useful	Could be adjusted	Very Helpful	Strongly Agree	Manageable	Very Interesting	Probably
09/06/2025 15:52:21	Nishanth C P	1KS23 CS097	Excellent	Very Relevant	Just Right	Very Useful	Just Right	Very Helpful	Strongly Agree	Manageable	Very Interesting	Definitely
09/06/2025 15:52:45	Shama Shivaraj Shetty	1KS23 CS144	Excellent	Very Relevant	Just Right	Very Useful	Just Right	Very Helpful	Strongly Agree	Manageable	Very Interesting	Definitely
09/06/2025 15:59:35	Vigasini S	1KS23 CS178	Good	Very Relevant	Challenging	Very Useful	Just Right	Very Helpful	Somewhat Agree	Manageable	Very Interesting	Probably
09/06/2025 16:08:58	Swathi G A	1KS24 CS414	Excellent	Very Relevant	Challenging	Very Useful	Could be adjusted	Very Helpful	Strongly Agree	Too Heavy	Very Interesting	Definitely
09/06/2025 16:13:34	Khushi M P	1KS23 CS065	Excellent	Very Relevant	Just Right	Very Useful	Just Right	Very Helpful	Strongly Agree	Manageable	Very Interesting	Definitely
09/06/2025 16:14:22	KRITHI K A M	1KS23 CS066	Excellent	Very Relevant	Just Right	Very Useful	Just Right	Very Helpful	Strongly Agree	Manageable	Very Interesting	Definitely
09/06/2025	Srikanth Kashyap	1ks23 cs100	Excellent	Very Relevant	Just Right	Very Useful	Just Right	Very Helpful	Strongly	Manageable	Very Inter	Definitely

16:23:38									Agree		esting	
09/06/2025 16:23:45	Priyadarshini E P	1KS23 CS114	Excellent	Very Relevant	Just Right	Very Useful	Just Right	Very Helpful	Strongly Agree	Manageable	Very Interesting	Definitely
09/06/2025 16:40:26	Reema J	1KS23 CS124	Good	Very Relevant	Challenging	Very Useful	Just Right	Very Helpful	Strongly Agree	Too Heavy	Very Interesting	Definitely
09/06/2025 16:40:32	Manya BR	1KS23 CS083	Good	Somewhat Relevant	Challenging	Very Useful	Too Long	Very Helpful	Neutral	Manageable	Somewhat Interesting	Probably
09/06/2025 16:40:57	Lekhana k	1KS23 CS071	Excellent	Very Relevant	Challenging	Very Useful	Just Right	Very Helpful	Somewhat Agree	Manageable	Somewhat Interesting	Probably
09/06/2025 16:43:07	RAVI CHANDRA K	1KS23 CS122	Excellent	Very Relevant	Challenging	Very Useful	Just Right	Very Helpful	Strongly Agree	Manageable	Very Interesting	Definitely
09/06/2025 16:43:37	Asiya Naaz	1KS23 CS021	Excellent	Very Relevant	Challenging	Very Useful	Just Right	Very Helpful	Strongly Agree	Variable	Very Interesting	Probably
09/06/2025 16:48:41	Bhavitha. E. G	1KS24 CS401	Excellent	Very Relevant	Challenging	Very Useful	Just Right	Very Helpful	Somewhat Agree	Manageable	Very Interesting	Probably
09/06/2025 16:51:42	Ameena Fathima	1KS23 CS009	Good	Somewhat Relevant	Challenging	Very Useful	Could be adjusted	Very Helpful	Strongly Agree	Manageable	Very Interesting	Definitely
09/06/2025 16:59:40	Rudresh S C	1KS23 CS127	Excellent	Very Relevant	Challenging	Very Useful	Just Right	Very Helpful	Strongly Agree	Manageable	Very Interesting	Definitely
09/06/2025 17:02:30	Rashmi Soni	1KS23 CS121	Excellent	Very Relevant	Just Right	Very Useful	Just Right	Very Helpful	Strongly Agree	Manageable	Very Interesting	Definitely
09/06/2025	Amrutha J	1KS23 CS011	Excellent	Very Relevant	Easy	Very Useful	Too Short	Very Helpful	Strongly Agree	Manageable	Very Interesting	Definitely

17:10:10													
09/06/2025 17:24:48	Jeevan M	1KS23 CS060	Excellent	Very Relevant	Just Right	Very Useful	Just Right	Very Helpful	Strongly Agree	Too Heavy	Very Interesting	Definitely	
09/06/2025 17:39:25	Nagashree S	1KS24 CS405	Excellent	Very Relevant	Easy	Very Useful	Just Right	Very Helpful	Strongly Agree	Too Light	Very Interesting	Definitely	
09/06/2025 17:43:57	Hemant h rajeurs HK	1KS23 CS051	Good	Very Relevant	Challenging	Very Useful	Just Right	Somewhat Helpful	Somewhat Agree	Manageable	Very Interesting	Definitely	
09/06/2025 17:47:14	Navya.K	1KS24 CS406	Excellent	Very Relevant	Just Right	Very Useful	Just Right	Very Helpful	Strongly Agree	Manageable	Very Interesting	Definitely	
09/06/2025 17:50:18	SAHAN A D	1KS23 CS136	Excellent	Very Relevant	Challenging	Very Useful	Just Right	Very Helpful	Strongly Agree	Manageable	Very Interesting	Definitely	
09/06/2025 17:54:15	Lavanya R	1KS23 CS069	Excellent	Very Relevant	Challenging	Very Useful	Just Right	Very Helpful	Strongly Agree	Manageable	Very Interesting	Definitely	
09/06/2025 18:21:49	Sakshi Ramesh	1KS23 CS137	Excellent	Very Relevant	Just Right	Very Useful	Just Right	Very Helpful	Strongly Agree	Manageable	Very Interesting	Definitely	
09/06/2025 18:46:47	PRANA VIKA. M	1KS23 CS112	Excellent	Very Relevant	Easy	Somewhat Useful	Too Long	Very Helpful	Somewhat Agree	Manageable	Very Interesting	Definitely	
09/06/2025 19:39:23	KAVYA SHREE R	1KS23 CS063	Excellent	Very Relevant	Challenging	Very Useful	Just Right	Very Helpful	Strongly Agree	Manageable	Very Interesting	Definitely	
09/06/2025 20:33:00	Akshaya B	1KS23 CS008	Good	Very Relevant	Just Right	Very Useful	Just Right	Very Helpful	Somewhat Agree	Manageable	Very Interesting	Probably	
09/06/2025 20:58:02	Aishwarya B C	1KS23 CS004	Good	Somewhat Relevant	Easy	Somewhat Useful	Just Right	Very Helpful	Strongly Agree	Manageable	Very Interesting	Probably	

09/06/2021:10:02	Manaswini Anand	1KS23CS079	Good	Very Relevant	Just Right	Very Useful	Just Right	Very Helpful	Strongly Agree	Manageable	Very Interesting	Definitely
10/06/2021:07:18:04	namrathamh	1ks23cs090	Excellent	Very Relevant	Just Right	Very Useful	Just Right	Very Helpful	Strongly Agree	Manageable	Very Interesting	Definitely
10/06/2021:09:10:29	Mohammad Sufiyaan Meccai	1KS23CS084	Excellent	Very Relevant	Just Right	Very Useful	Just Right	Very Helpful	Strongly Agree	Manageable	Very Interesting	Definitely
10/06/2021:09:18:50	Pragathiswari	1KS23CS082	Good	Very Relevant	Challenging	Very Useful	Too Long	Somewhat Helpful	Somewhat Agree	Manageable	Very Interesting	Definitely
10/06/2021:09:48:10	Raziya khan	1KS23CS123	Excellent	Very Relevant	Just Right	Very Useful	Just Right	Very Helpful	Strongly Agree	Manageable	Very Interesting	Definitely

Impact Analysis

1. How was the project experience	2. How relevant was the project to the course?	3. How would you rate the difficulty level?	4. How useful was the Project in Understanding DBMS Concept?	5. How would you rate the project Duration?	6. How was the Guidance Provided?	7. Did the project enhance your problem solving skill?	8. How would you rate the project workload?	9. How would you rate the project topic?	10. Would you suggest this project to others?
100%	100%	89%	95%	92%	94%	90%	92%	95%	95%

Mapping table for a DBMS mini project:

Program Outcomes (POs) Mapping to Project

- PO1: Engineering Knowledge Applied DBMS concepts to design and develop the project
- PO2: Problem Analysis Analyzed data management problems and proposed solutions
- PO3: Design/Development of Solutions Designed and developed a database system
- PO4: Conduct Investigations Evaluated database performance and optimized queries
- PO5: Modern Tool Usage Utilized DBMS software (e.g., MySQL) for project development
- PO9: Individual and Team Work Collaborated with team members to complete the project
- PO10: Communication presented the project and its outcomes effectively
- PO12: Life-long Learning Learned and applied new DBMS concepts and tools

Justification:

Mapping table with 3 levels of attainment:

Program Outcomes (POs) Mapping to Project Attainment Level (1-3)

PO1: Engineering Knowledge:Applied DBMS concepts to design and develop the project	2
PO2: Problem Analysis;Analyzed data management problems and proposed solutions	2
PO3: Design/Development of Solutions;Designed and developed a database system	3
PO5: Modern Tool Usage.Utilized DBMS software (e.g., MySQL) for project development	2
PO9: Individual and Team Work;Collaborated with team members to complete the project	2
PO10: Communication;Presented the project and its outcomes effectively	2

Attainment Levels

1. Basic understanding/application
2. Moderate application/analysis
3. Advanced application/analysis (exceeded expectations)

PO mapping to Project Attainment Level:

Mini project exhibition	PO1	PO2	PO3	PO4	PO5	PO6	PO7	PO8	PO9	PO10	PO11	PO12
DBMS Mini Project Exhibition	2	2	3	-	2	-	-	-	2	2	-	-

Coordinators

Prof. T Somasekhar

Dr.Soubhagya Lakshmi

Prof.Sumarajesh

Prof..Beena K

T. Somasekhar

HOD

Head of the Department
Dept. of Computer Science & Engg
K.S. Institute of Technology
Bengaluru - 560 109

K. S. Kumar

Principal

PRINCIPAL
K.S. INSTITUTE OF TECHNOLOGY
BENGALURU - 560 109



K.S. INSTITUTE OF TECHNOLOGY, BANGALORE - 560109
DEPARTMENT OF COMPUTER SCIENCE AND ENGINEERING
CONTENT BEYOND THE SYLLABUS

Academic Year	2024-25 (EVEN)
Name of the Faculty	Dr. JALAJA P Dr. VENKATARAMANA B S Mrs. REKHA R
Course Name /Code	Discrete Mathematical Structures /BCS405A
Semester/Branch	IV/CSE
Activity Name	LECTURE
Topic Covered	Group Theory Applications in Cryptography
Date	05/05/2025
No. of Participants	197
Objectives/Goals	<ul style="list-style-type: none">• To introduce the basic concepts of group theory relevant to cryptography• To explain how groups support the development of encryption algorithms• To demonstrate real-world cryptographic systems based on group theory
ICT Used	PPT
Appropriate Method/Instructional materials/Exam Questions The lecture was given on the topic Group Theory Applications in Cryptography on 5/05/2025. By exploring the intersection of algebra and computer science, this topic enables students to see the vital role of mathematical theory in securing digital communications. Group theory not only enhances theoretical knowledge but also opens pathways for future study in cyber security and cryptographic engineering.	
Relevant PO's	1,2,5,9 and 12
Significance of Results/Outcomes	<ul style="list-style-type: none">• Students able to improve their knowledge.• Understand core group properties and their mathematical importance• Relate group theory to modern cryptographic techniques.
Reflect Critique	<ul style="list-style-type: none">• This enhances the understanding of relations and functions by connecting them to real-world applications in secure communication.

Proof:

SUMMARY

Cryptography is a field of study and practice that focuses on securing communication, data, and information by converting it into a form that is unintelligible to unauthorized parties. Here is a summary of cryptography:

- **Purpose:** Cryptography is primarily used to ensure the confidentiality, integrity, and authenticity of data and communications. It protects information from eavesdropping, tampering, and unauthorized access.
- **Encryption:** Encryption is a fundamental technique in cryptography. It involves converting plaintext (original data) into ciphertext (unreadable data) using an algorithm and a cryptographic key. Only those with the correct key can decrypt and access the original data.
- **Decryption:** Decryption is the reverse process of encryption. It converts ciphertext back into plaintext using the appropriate key. This ensures that authorized users can access and understand the data.
- **Key Management:** Cryptography relies heavily on cryptographic keys. Keys can be symmetric (same key for encryption and decryption) or asymmetric (public and private keys). Proper key management is essential to maintain security.
- **Applications:** Cryptography is used in various applications, including secure communication over the internet (e.g., HTTPS), secure storage of sensitive data, electronic payments (e.g., cryptocurrencies), and securing military and government communications.
- **Challenges:** Cryptography faces ongoing challenges, such as the development of quantum-resistant encryption methods (due to the potential threat of quantum computers), balancing security with usability, and addressing the evolving landscape of cyber threats.
- **In summary,** cryptography plays a crucial role in safeguarding sensitive information and enabling secure digital communication in an increasingly interconnected world. It employs mathematical techniques and algorithms to protect data from unauthorized access and manipulation.

CHALLENGES:

While cryptography is a powerful tool for securing information, it also presents several challenges, including:

- **Key management:** Cryptography relies on the use of keys, which must be managed carefully to maintain communication security.
- **Quantum computing:** The development of quantum computing poses a potential threat to current cryptographic algorithms, which may become vulnerable to attacks.
- **Human error:** Cryptography is only as strong as its weakest link, and human error can easily compromise communication security.

MATHEMATICS USED IN CRYPTOGRAPHY:

- **Does Cryptography Need Math?**
- Mathematics is the foundation of most complex systems, including IT. Therefore, most professionals dealing with computer systems are proficient in math. However, does cryptography need math?
- "Mathematics forms the basis of cryptography. Therefore, you should be alert to math concepts and applications to pursue a cryptology career. It employs encryption and decryption algorithms, all of which are mathematical models. If you don't have a degree in mathematics, it is best to take a math course."
- Therefore, having a mathematical background gives you an upper hand when learning cryptography or any other related skill. Professional cryptographers are trained in mathematics. Besides the creation and manipulation of algorithms, you need to understand the relation between digital signatures.

<https://drive.google.com/file/d/1E4ULC-six7GUiXFBHYyV49PDIEh3n0Ab/view?usp=sharing>

Signature of Course Incharge

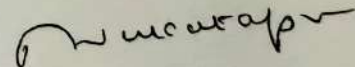
Signature of HOD

Head of the Department
Dept. of Computer Science & Engg
K.S. Institute of Technology
Bengaluru -560 109



K.S. INSTITUTE OF TECHNOLOGY, BANGALORE - 560109
DEPARTMENT OF COMPUTER SCIENCE AND ENGINEERING
TEACHING AND LEARNING

CONTENT BEYOND SYLLABUS REPORT

Academic Year	2024-2025 (EVEN)
Name of the Faculty	NAMYAPRIYA D
Course Name /Code	UI/UX / BCS456C
Semester/Section	IV/ A, B & C
Activity Name	VALUE ADDED CERTIFICATIONS ON AI
Topic Covered	User Inter Design and User Experience (UI/UX)
No. of Participants	
Objectives/Goals	<ol style="list-style-type: none">1. Understand the Basics of UI and UX Learn what UI (User Interface) and UX (User Experience) mean and why they are important.2. Identify Good and Bad Design Look at examples and explain what makes a design user-friendly or confusing.3. Create Simple Wireframes and Prototypes Draw basic layout ideas and use tools to build simple screen designs.4. Use Design Thinking Process Learn how to understand user problems and come up with design ideas using steps like empathize, define, ideate, prototype, and test.5. Design with Users in Mind Think about user needs, behaviors, and goals while creating digital products.6. Work with Basic Design Tools Get hands-on experience using tools like Figma or Adobe XD for UI/UX design.7. Test and Improve Designs Learn how to get feedback on your designs and make them better.
ICT Used	E-Learning
Appropriate Method/Instructional Materials/Exam Questions: Methods: <ol style="list-style-type: none">1. Self-paced learning through online certification platforms.2. Guided mentoring sessions to clarify concepts and troubleshoot practical challenges.3. Peer learning through group discussions on project implementations.4. Periodic assessments via quizzes, coding challenges, and practical assignments. Instructional Materials: <ol style="list-style-type: none">1. Video tutorials from industry experts on Coursera, Infosys Springboard, Swayam, and NPTEL.2. Comprehensive guides and documentation for tools like Figma, Adobe XD, or Sketch	
Relevant CO's	CO1: Gain knowledge of advanced UI/UX concepts beyond the syllabus, including current industry trends, tools, and design systems. CO2: Develop practical design skills by working on real-world projects and completing relevant certification programs. CO3: Understand the ethical and societal implications of UI/UX design, including accessibility, inclusivity, and user data privacy.

	CO4: Build a strong foundation for continuous learning and professional growth in the field of UI/UX design.
Relevant PO's:	PO1, PO3, PO4, PO6, PO7
Significance of Results/Outcomes	<p>Career Advancement</p> <ul style="list-style-type: none"> • UI/UX certifications validate design and technical skills, increasing employability. • Students become well-prepared for roles such as UI/UX designers, interaction designers, user researchers, and product designers. <p>Skill Enhancement</p> <ul style="list-style-type: none"> • Hands-on exposure to real-world design challenges ensures students are industry-ready. • Certification projects help students build confidence in applying user-centered design principles and using industry tools like Figma, Adobe XD, etc. <p>Global Competitiveness</p> <ul style="list-style-type: none"> • Certifications from global platforms (e.g., Coursera, Google UX Design, Swayam) boost international recognition. • Students gain a competitive edge for higher education and careers in global design firms or tech companies. <p>Broader Impact</p> <ul style="list-style-type: none"> • Awareness of ethical, inclusive, and accessible design promotes socially responsible UX practices. • Trained professionals contribute to creating sustainable, inclusive, and human-centered digital experiences across various industries.
Reflective Critique	<p>Strengths</p> <ul style="list-style-type: none"> • The integration of value-added UI/UX certifications bridges the gap between academic theory and industry design practices. • Self-paced learning allows students to explore specific areas of interest like user research, prototyping, or accessibility, at their own pace. <p>Areas for Improvement</p> <ul style="list-style-type: none"> • Some UI/UX certifications may require prior knowledge of tools or design basics; offering introductory workshops can help bridge this gap. • Access to premium design courses may be limited by cost; highlighting financial aid or free alternatives (like Google UX Design or Swayam) can support inclusion. <p>Potential Enhancements</p> <ul style="list-style-type: none"> • Institutions can offer academic credit or recognition for completion of reputed UI/UX certifications. • Encourage collaborative design projects where students apply certification knowledge to solve local community issues or user experience challenges in real industries. <p>Broader Implications</p> <ul style="list-style-type: none"> • Integrating value-added certifications ensures students stay aligned with rapidly evolving trends in design and technology. • Promotes a culture of continuous learning, helping students stay adaptable and relevant in the global design and tech landscape.

Proofs:

Sample copy of the certificate attached



||| COURSE COMPLETION CERTIFICATE |||

The certificate is awarded to

Aryaman Tiwari

for successfully completing the course

UX and UI - Designing with Color Theory

on June 5, 2025



Congratulations! You make us proud!

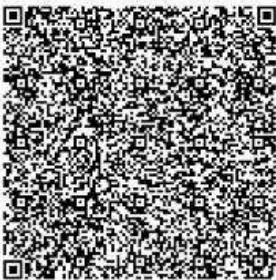

Issued on: Saturday, June 7, 2025
To verify, scan the QR code at <https://verify.onwingspan.com>

Thirumala Arohi
Executive Vice President and Global Head
Education, Training & Assessment (ETA)
Infosys Limited

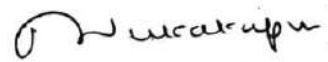

Signature of Course In-charge



Signature of HOD
Head of the Department
Dept. of Computer Science & Engg
K.S. Institute of Technology
Bengaluru -560 109

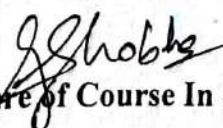

Content Beyond Syllabus

Academic Year	2024-2025 (Even)
Name of the Faculty	Dr. Shobha G
Course Name/Code	Biology for Engineers / BBOC407
Semester/Section	IV/CSE-A,B,C
Activity Name	Online certificate course Coursera- Access Bioinformatics Database with Biophyton Cursa-Introduction to Biology by the new boston (1hr 41min) Infosys-Springboard-Cell –The Structure and Function Udemy-Learn Bioinformatics from scratch (Theory & practical) (8.5 hr)
Topic Covered	Related to Biology and Application of Biology in engineers
Date	June-2025
No. of Participants	201
Objectives/Goals	Objectives <ul style="list-style-type: none">• To improve Engineering knowledge in field of Biology• To improve the self-learning skills of students• To improve the confidence, communication level
ICT Used	-
Appropriate Method/Instructional materials/Exam Questions <ul style="list-style-type: none">• Prior information was given to students to select the topics and to do the course	
Relevant PO'S	PO1, PO2, PO3, PO5, PO6, PO7, PO10
Significance of outcomes	Students able to Improve their knowledge in biology and its application.
Reflective Critique	The activity improved the learning, communication skills
Proof	Certificate

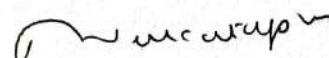
Signature of Course In charge

Signature of HOD



K.S. INSTITUTE OF TECHNOLOGY, BANGALORE - 560109
DEPARTMENT OF COMPUTER SCIENCE AND ENGINEERING
TEACHING AND LEARNING

CONTENT BEYOND SYLLABUS REPORT

Academic Year	2024-2025 (EVEN)																		
Name of the Faculty	Mrs. Amritha R.																		
Course Name /Code	Universal Human Values (BUHK408)																		
Semester/Section	IV/A																		
Activity Name	Poster making																		
Topic Covered	<table border="1"><tr><td>Mother Teresa</td></tr><tr><td>Swami Vivekananda</td></tr><tr><td>Dr. APJ Abdul kalam</td></tr><tr><td>Kalpana chawla</td></tr><tr><td>Mary Kom</td></tr><tr><td>Ratan Tata</td></tr><tr><td>Rabindranath Tagore</td></tr><tr><td>Mark Zuckerberg</td></tr><tr><td>Steve Jobs</td></tr><tr><td>Bhagat Singh</td></tr><tr><td>Indira Gandhi</td></tr><tr><td>B.R. Ambedkar</td></tr><tr><td>Bal Gangadhar Tilak</td></tr><tr><td>Sardar Vallabhbhai patel</td></tr><tr><td>Sarojini Naidu</td></tr><tr><td>P.T.Usha</td></tr><tr><td>Shakuntala Devi</td></tr></table>	Mother Teresa	Swami Vivekananda	Dr. APJ Abdul kalam	Kalpana chawla	Mary Kom	Ratan Tata	Rabindranath Tagore	Mark Zuckerberg	Steve Jobs	Bhagat Singh	Indira Gandhi	B.R. Ambedkar	Bal Gangadhar Tilak	Sardar Vallabhbhai patel	Sarojini Naidu	P.T.Usha	Shakuntala Devi	
Mother Teresa																			
Swami Vivekananda																			
Dr. APJ Abdul kalam																			
Kalpana chawla																			
Mary Kom																			
Ratan Tata																			
Rabindranath Tagore																			
Mark Zuckerberg																			
Steve Jobs																			
Bhagat Singh																			
Indira Gandhi																			
B.R. Ambedkar																			
Bal Gangadhar Tilak																			
Sardar Vallabhbhai patel																			
Sarojini Naidu																			
P.T.Usha																			
Shakuntala Devi																			
No. of Participants	67																		
Objectives/Goals	<ul style="list-style-type: none">• To understand the topic more precisely• To improve the self-learning skills of students.• To learn about human values from great leaders.• To connect moral values with real-life actions.• To understand the importance of values like empathy, integrity and sustainability.																		
ICT Used	Canva app, Poster Maker																		

Appropriate Method/Instructional Materials/Exam Questions:

1. Students were asked to prepare a Poster on the Great leaders across the world.
2. Students were expected to learn about the values from the great leader's behavior towards the society.

Relevant PO's:	PO5, PO8, PO9, PO10, PO12
Significance of Results/Outcomes	<ul style="list-style-type: none"> • Students were able to understand about the life and achievements of the great leaders across the world. • 17 groups presented details of the great leaders and role models.
Reflective Critique	<ul style="list-style-type: none"> • The activity helped students to analyze how to visually represent abstract ideas. • The activity helped the students to use layout, symbols and text to convey a message. • The activity helped the students develop sensitivity to social issues and human behavior.

List of topics selected by students	Group no.	USN	Name of the Students	Topic
	1		IKS23CS029	CHARAN SAI TEJ
		IKS23CS025	BHUVAN	
		IKS23CS001	ABHIMANYU	
		IKS23CS019	ARUN CHAVAN	
2		IKS23CS012	AMULYA V	Swami Vivekananda
		IKS23CS014	ANUJA V M	
		IKS23CS021	ASIYA NAAZ	
		IKS23CS028	CHAITRA N KIRANAGI	
3		IKS23CS046	GAGANA POOJARI	Dr. APJ Abdul kalam
		IKS23CS049	GAYANA V	
		IKS23CS022	BHAGYASHREE	
		IKS23CS050	MADHU PRATHIKA G	
4		IKS23CS043	DURGASHREE M	Kalpana chawla
		IKS23CS018	ARPITA RATHOD	
		IKS23CS406	NAVYA P	
		IKS23CS417	YASHASWINI	
5		IKS23CS057	HARSHITHA REDDY	Mary Kom
		IKS23CS061	JEEVITHA A P	
		IKS23CS008	AKSHAYA	
		IKS23CS039	DEEPIKA	
6		IKS23CS026	BRINDA G	Ratan Tata
		IKS23CS015	ANUSHA V	
		IKS23CS023	BHAVANI S	

	1KS23CS002	ADITI S H	
7	1KS23CS051	H K HEMANTH RAJE URS	Rabindranath Tagore
	1KS23CS006	AKASH R	
	1KS24CS407	PAVAN KUMAR M	
	1KS23CS411	RAKESH J	
8	1KS23CS060	JEEVAN M	Mark Zuckerberg
	1KS23CS036	CHIRANTH GOWDA S	
	1KS23CS003	ADITYA A	
	1KS23CS056	HARSHITH K	
9	1KS23CS034-	CHIRAG T	Steve Jobs
	1KS23CS045-	GC LIKITH CHOWDARY	
	1KS23CS052	HL DARSHAN	
	1KS23CS055	HARSHAVARDHAN	
10	1KS23CS042	DHEERAJ MS	Bhagat Singh
	1KS23CS041	DHEERAJ A	
	1KS23CS033	CHINMAY BH	
	1KS23CS053	HARISH DEEKSHIT	
	1KS23CS416	VARUN S	
11	1KS23CS031	CHETAN D	Indira Gandhi
	1KS23CS037	DARSHAN G	
	1KS23CS040	DHANUSH J	
	1KS23CS047	GANESH M	
12	1KS23CS004	AISHWARYA BC	B.R. Ambedkar
	1KS23CS011	AMRUTHA J	
	1KS23CS017	APOORVA R NAVDA	
13	1KS23CS059	JAYADITYA DEV	Bal Gangadhar Tilak
	1KS23CS020	ARYAMAN TIWARI	
	1KS23CS054	HARSH MISHRA	
	1KS23CS048	GARV B J	
14	1KS23CS009	AMEENA FATHIMA	Sardar Vallabhbhai patel
	1KS23CS027	C SINDHU	
	1KS23CS038	DEEKSHA J	
15	1KS23CS016	ANVITHA T.A	Sarojini Naidu
	1KS23CS035	CHIRANTH G	

		IKS23CS005	AISHWARYA N	
		IKS23CS030	CHARAN TEJA GS	
16		IKS23CS013	ANGELINA SHARON ROBERT	P.T.Usha
		IKS23CS062	K HARINI	
		IKS23CS058	JANHAVI M	
		IKS23CS024	BHOOMIKA M H	
17		IKS23CS007	AKASH S	Shakuntala Devi
		IKS23CS010	AMRUTH CK	
		IKS23CS032	NAGENDRA REDDY	
		IKS23CS044	G AKASH	

Proofs :

Sample copy of the posters attached

K S INSTITUTE OF TECHNOLOGY
#14, Raghuvanahalli, Kanakapura main road, Bengaluru
DEPARTMENT OF COMPUTER SCIENCE AND ENGINEERING

MARK ZUCKERBERG

Biography

- Born May 14, 1984, White Plains, New York
- Studied at Harvard University
- Created Facebook in 2004
- Faced early legal challenges and rapid growth

Human Values

- Innovation and vision
- Perseverance and dedication
- Leadership and adaptability
- Social responsibility and philanthropy

Challenges Faced

- Legal disputes and controversies
- Data privacy and ethical issues
- Criticism from media and public
- Continued focus on growth and responsibility

Lessons for Students

- Think creatively and innovate
- Face challenges with resilience
- Lead ethically and responsibly
- Apply values in academics and life

Impact & Legacy

- Changed the way people connect globally
- Founder of Meta, leading AI developments
- Philanthropic work through Chan Zuckerberg Initiative
- Named among world's most influential personalities



AWARDS

Padma Bhushan
 Padma Vibhushan
 Honorary Knight Grand Cross of the Order of the British Empire
 Carnegie Medal of Philanthropy
 Commander of the Legion of Honour

RATAN TATA

BIOGRAPHY

Ratan Tata (born December 28, 1927, Bombay (now Mumbai), India—died October 9, 2024, Mumbai) was an Indian businessman who became chairman (1991–2012 and 2016–17) of the *Tata Group*.

CORE HUMAN VALUES

Ethical Leadership
 Humility
 Integrity
 Respect



LESSONS FOR STUDENTS

Embrace Innovation and Adaptation
 Value of Ethics and Integrity
 Commitment towards Social Responsibility
 Long-term Focus
 Mentorship and Team Building
 Courage to Take Risk

CHALLENGES

Reviving Struggling Companies:
 Opposition Within the Tata Group
 Global Acquisitions
 Launching the Tata Nano
 Ethical Leadership
 Economic and Political Challenges
 Philanthropic Vision

IMPACTS



ADITYA S.H. 1KS23CS008 BHAVANI R. 1KS23CS023
 ANURAG V. 3KS23CS005 SHINHA G. 1KS23CS016



K. S. INSTITUTE OF TECHNOLOGY

#14 Raghuvanahalli Kanakapura road
 Bangalore-560109

Affiliated to VTU, Belagavi and approved by AITCE New Delhi

Department of Computer Science and Engineering



"Swami Vivekananda: A Beacon of Wisdom and Strength"

- Full Name: Swami Vivekananda (born Narendranath Dutta)
- Birth Date: 12 January 1863
- Death Date: 4 July 1902
- Famous For: Introducing Indian philosophies of Vedanta and Yoga to the West; Inspiring national pride in India.

Famous Achievements:

- Delivered the famous speech at Parliament of the World's Religions (Chicago, 1893) – beginning with "Sisters and Brothers of America."
- Founder of the Ramakrishna Mission (1897).



Father: Vishwanath Datta
 A well-educated and successful attorney at the Calcutta High Court.

Mother: Bhuvaneshwari Devi
 A devout religious and strong-willed woman.

He was widely honored for his brilliant speech and presence.

"The press in America called him 'The Cyclic Monk from India.'"

After returning to India in 1897, he received a hero's welcome.

Inspirational Quotes:

"The greatest sin is to think yourself weak."

"Arise! Awake! and stop not until the goal is reached."

"Take risks in your life. If you win, you can lead. If you lose, you can guide."



1KS23CS012 - AMULYA
 1KS23CS014 - ANUJA
 1KS23CS021 - ASYA
 1KS23CS028 - CHAITRA



Sardhar Vallabhai Patel was born on October 31, 1875, in Nadiad, Gujarat. He showed leadership qualities from a young age and was known for his determination and courage.

CHALLENGES FACED AND HOW THEY STOOD BY THEIR VALUES:

1. Integration of Princely States
2. Post-Independence Governance



LEGACY:

"IRON MAN OF INDIA" known for his firmness and decisive leadership, Patel is remembered as a symbol of strength and unity. The world's tallest statue, called the statue of unity was built in his honor in Gujarat.

His leadership in integrating over 560 princely states into Indian union laid the foundation for a strong, united nation. As India's first deputy Prime minister and home minister his firm resolves.

Signature of Course In charge

Signature of HOD

Head of the Department
 Dept. of Computer Science & Engg
 K. S. Institute of Technology
 Bengaluru -560 109

**KSIT**

K.S. INSTITUTE OF TECHNOLOGY, BANGALORE – 560109
DEPARTMENT OF COMPUTER SCIENCE &ENGINEERING
TEACHING AND LEARNING
CONTENT BEYOND SYLLABUS

Academic year	2024-2025 (Even)
Name of the Faculty	Kodur Srividya
Course Name/Code	Universal Human Values (UHV) / BUHK408
Semester/Section	IV / C
Activity Name	Poster Presentation
Date	02-04-2025 & 03-04-2025
No. of participants	66/66
Topic Covered	<ol style="list-style-type: none">1. Mother Teresa2. Swami Vivekananda3. Dr APJ Abdul kalam4. Kalpana Chawla5. Mary Kom6. Ratan Tata7. Rabindranath Tagore8. Mark Zuckerberg9. Steve Jobs10. Bhagat Singh11. B.R. Ambedkar12. Bal Gangadhar Tilak13. Sardar Vallabhbhai Patel14. Elon Musk15. P.T. Usha
Objectives/Goals	<ul style="list-style-type: none">• To improve the self-learning and presentation skills of students.• To improve the communication skills of students.
ICT Used	Laptop, PPT
Appropriate method/Instructional materials/Exam questions	<ul style="list-style-type: none">• Students were formed into groups, assigned with a topic, asked to prepare A3 size poster.• Students are given with additional information/ sources from which they can prepare.
Relevant Po's	PO9, PO10, PO11, PO12
Significance of Results/Outcomes	The students were able to understand and show the Teamwork, Improved the presentation skills and Improved Emotional Quotient.
Reflective Critique	The main goal of this is to provide a platform for students to interact with their peers and work on unique topics which helps them to be a knowledgeable and responsible individual with extraordinary human values.

Proofs:

<https://drive.google.com/drive/folders/16hiSAZYsBgIy-l2Rqi7iLHceRG2yahKm?usp=sharing>

Samples:



K. S INSTITUTE OF TECHNOLOGY BANGALORE-560109
 Sakshi Ramesh- 1KS23CS137, Sahana.D- 1KS23CS136, Yashaswini.K.T- 1KS23CS187, Yuinam Thanuja-1KS23CS185(C SEC)

Department of Computer Science and Engineering

KALPANA CHAWLA

INTRODUCTION

Human values refer to the principles, beliefs, and standards of behavior that guide how individuals interact with one another and the world around them like honesty-Being truthful and sincere in words,Compassion - Showing empathy and concern for the well-being of others.

Learning human values from famous personalities is important because it provides us with real-life examples of how to live with integrity, compassion, and purpose.

Kalpana Chawla's personality can be described as determined, ambitious, resilient, and inspiring. She possessed a strong passion for exploration and knowledge, which drove her to pursue a career in aerospace engineering and space exploration.

Chawla's personality was marked by a deep sense of perseverance. Despite facing numerous challenges, including being a woman in a male-dominated field and coming from a modest background, she never gave up on her dreams.

BIOGRAPHY

Kalpana Chawla was born on March 17, 1962, in Karnal, Haryana, India. She was born into a modest family, with her father, a textile manufacturer, encouraging her to pursue her dreams.

She completed her schooling at the Tagore School in Karnal, excelling in her studies. She pursued a Bachelor's degree in Aeronautical Engineering from Punjab Engineering College, Chandigarh, in 1982. She earned a Master's degree in Aerospace Engineering from the Texas university at Arlington in 1984. Kalpana went on to earn a Ph.D. in Aerospace Engineering from the University of Colorado in 1988.

STRUGGLES

As a woman in a male-dominated field, she faced several challenges, including discrimination and cultural differences.

In 1995, Kalpana Chawla joined NASA as a mission specialist astronaut, making her the first woman of Indian origin to fly in space. Her first space mission was aboard the Space Shuttle Columbia in 1997 during STS-87, where she conducted scientific experiments. Kalpana's second mission was aboard Columbia in 2003 as part of the STS-107 mission.



CONCLUSION

Kalpana Chawla's life and legacy serve as a powerful reminder of the impact of determination, resilience, and the pursuit of one's dreams. As the first woman of Indian origin in space, she broke barriers in a male-dominated field, inspiring millions around the world, especially women and young girls, to aim for the stars.

IMPACT AND LEGACY

Chawla's achievements in the aerospace field, particularly as a woman from India, broke cultural and gender barriers, inspiring many young girls and aspiring scientists worldwide. After her tragic death in the Columbia disaster in 2003, Kalpana Chawla's legacy continued to inspire many in science, technology, engineering, and mathematics (STEM). Schools, institutions, and organizations in India and the U.S. have been named in her honor, and various scholarships and awards have been established in her name.

Kalpana Chawla's life is a testament to courage, dedication, and perseverance, making her an enduring symbol of inspiration to many. Kalpana Chawla's legacy is not only in her groundbreaking achievements but also in the courage and values she embodied - showing us that with perseverance and a love for what we do, we can leave a lasting impact on the world.



List of topics and details:

BATCH NUMBER	USN	NAME	TOPIC
1	1KS23CS132	S V Navya	
	1KS23CS144	Shama Shivaraj Shetty	
	1KS23CS156	Shrusti L	Mother Teresa
	1KS23CS167	Thanushree V S	
	1KS23CS178	Vigasini S	
2	1KS23CS138	Sandhya	
	1KS23CS149	Shravya Prakash	
	1KS23CS172	Varsha SK	Swami Vivekananda
	1KS23CS170	Varsha DR	
	1KS23CS188	Yashaswini S	
3	1KS23CS158	Sravya Illuri	
	1KS23CS159	Srigowri S Kulkarni	
	1KS23CS164	Talluru Sahithya	Dr APJ Abdul kalam
	1KS23CS179	Vijayalakshmi C	
	1KS23CS186	Yashaswi R	
4	1KS23CS137	Sakshi Ramesh	
	1KS23CS136	Sahana D	
	1KS23CS187	Yashaswini K T	Kalpana Chawla
	1KS23CS185	Vunnam Thanuja	
5	1KS23CS129	S Avinash	
	1KS23CS130	S Harsha	
	1KS23CS145	Shamith Gowda	Mary Kom
	1KS23CS184	Vishal Vass	
6	1KS23CS135	Sagarika Patil	
	1KS23CS169	Varnika G	
	1KS23CS140	Sanjana N	Ratan Tata
	1KS23CS155	Shrusti L	
7	1KS23CS171	Varsha Dattatreya Bhat	
	1KS23CS126	Rubykumari R	
	1KS24CS415	Varshini J	Rabindranath Tagore
	1KS24CS409	Rachana	
8	1KS23CS134	Sadhana M	
	1KS23CS162	Surekha TS	
	1KS23CS163	Sriraga	Mark Zuckerberg
	1KS23CS173	Varshitha	

9	1KS23CS128	Rushitha K	
	1KS23CS139	Sanjana Jagannatha	
	1KS23CS150	Shreya S	Steve Jobs
	1KS23CS151	Shreya S Upadhya	
10	1KS23CS127	Rudresh Siddappa Chakrasali	
	1KS23CS152	Shreyas S	
	1KS23CS160	Sudarshan Veerabhadrapa Gondi	Bhagat Singh
	1KS23CS176	Veerendra R	
	1KS23CS177	Venkat S S	
11	1KS23CS148	Shivamani N	
	1KS23CS168	Ujwal G Naik	
	1KS23CS157	Somesh K N	B.R. Ambedkar
	1KS23CS166	Tarun R	
12	1KS23CS141	Sanjay T	
	1KS23CS180	Vikas K B	
	1KS24CS402	Darshan KR	Bal Gangadhar Tilak
	1KS24CS403	Gagan gowda	
13	1KS23CS143	Sarvagna S Rao	
	1KS23CS153	Shrihari IB	Sardar Vallabhbhai Patel
	1KS23CS154	Shrisha C M	
	1KS23CS161	Sudhanva K Joshi	
14	1KS23CS182	Vishal R	
	1KS23CS183	Vishal T K	Elon Musk
	1KS23CS175	Vatsal Vignesh B C	
	1KS23CS131	S Sumanth	
	1KS23CS181	Viniith M R	
15	1KS23CS146	Shashank Gowda U	
	1KS23CS147	Shiva M	P.T. Usha
	1KS23CS133	Sachin R	
	1KS23CS142	Sanketh Kumar K R	

K. Sridya

Signature of Course In charge

[Handwritten Signature]

Signature of HOD-CSE

Head of the Department
Dept. of Computer Science & Engg
K.S. Institute of Technology
Bengaluru -560 109



K.S. INSTITUTE OF TECHNOLOGY, BANGALORE - 560109
DEPARTMENT OF COMPUTER SCIENCE AND ENGINEERING
TEACHING AND LEARNING

CONTENT BEYOND SYLLABUS REPORT

Academic Year	2024-2025(EVEN)
Name of the Faculty	SHRUTHI T S
Course Name /Code	CLOUD COMPUTING/BCS601
Semester/Section	VI A
Activity Name	INFOSYS SPRINGBOARD: CERTIFICATE
Topic Covered	Module 1: Distributed System Models and Enabling Technologies Module 2: Virtual Machines and Virtualization of Clusters and DataCentres Module 3: Cloud Platform Architecture over Virtualized Datacenters Module 4: Cloud Security Module 5: Cloud Programming and Software Environments
No. of Participants	70
Objectives/Goals	<ul style="list-style-type: none">• Introduce the rationale behind the cloud computing revolution and the business drivers• Understand various models, types and challenges of cloud computing• Understand the design of cloud native applications, the necessary tools and the design trade-offs.• Realize the importance of Cloud Virtualization, Abstraction's, Enabling Technologies and cloud security.
ICT Used	Google forms
Appropriate Method/Instructional Materials/Exam Questions The students of the class were provided with the following: <ol style="list-style-type: none">1. Distributed System Models and Enabling Technologies2. Virtual Machines and Virtualization of Clusters and Data Centers3. Cloud Platform Architecture over Virtualized Datacenters4. Cloud Security and Trust Management5. Cloud Programming and Software Environments	
Relevant CO's	CO1,CO2,CO3,CO4,CO5
Relevant PO's:	PO1,PO2,PO4,PO5,PO12
Significance of Results/Outcomes	<ul style="list-style-type: none">• Students were able to understand the impact of cloud computing across technology, business, and society.
Reflective Critique	<ul style="list-style-type: none">• The main goal of a Cloud Computing quiz is to assess students' understanding and application of fundamental concepts, architectures, technologies, and real-world implications of cloud computing.
Proofs : Sample copy of the certificate attached https://forms.gle/33Gf6CQodentrWZG8	

||||| COURSE COMPLETION CERTIFICATE |||||

The certificate is awarded to

D S Aishwarya

for successfully completing the course

Cloud Computing

on May 10, 2025

Infosys | Springboard

Congratulations! You make us proud!

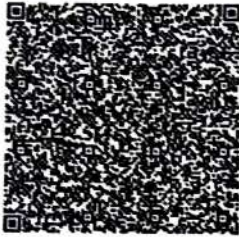

Issued on: Thursday, March 20, 2025
To verify, scan the QR code at <https://verify.onspringboard.com>

Thirumala Arohi
Executive Vice President and Global Head
Education, Training & Assessment (ETA)
Infosys Limited

||||| COURSE COMPLETION CERTIFICATE |||||

The certificate is awarded to

Anirudh M Mudambi

for successfully completing the course

Virtualization and Cloud Computing

on May 30, 2025

Infosys | Springboard

Congratulations! You make us proud!

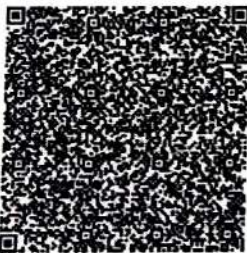

Issued on: Sunday, June 1, 2025
To verify, scan the QR code at <https://verify.onspringboard.com>

Thirumala Arohi
Executive Vice President and Global Head
Education, Training & Assessment (ETA)
Infosys Limited

Signature of Course In charge

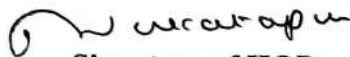
Signature of HOD
Head of the Department
Dept. of Computer Science & Engg
K.S. Institute of Technology
Bengaluru -560 109



K.S. INSTITUTE OF TECHNOLOGY, BANGALORE - 560109
DEPARTMENT OF COMPUTER SCIENCE AND ENGINEERING
TEACHING AND LEARNING

CONTENT BEYOND SYLLABUS REPORT

Academic Year	2024-25
Name of the Faculty	Mrs. Roopa Onkar Deshpande
Course Name /Code	Cloud Computing (BCS601)
Semester/Section	VI/B
Activity Name	Online Certification (Infosys Spring Board)
Topic Covered	<ol style="list-style-type: none">1. Introduction to cloud computing2. Essentials of Cloud Computing
No. of Participants	65
Objectives/Goals	<ul style="list-style-type: none">• To understand various models, types and challenges of cloud computing• To improve self-learning skills
ICT Used	E-Learning
Appropriate Method/Instructional Materials/Exam Questions: Infosys Springboard: Introduction to cloud computing Coursera : Foundation to Multi-Cloud	
Relevant CO's	CO1, CO2, CO3, CO4, CO5
Relevant PO's:	PO9, PO10, PO12
Significance of Results/Outcomes	<ul style="list-style-type: none">• Students were able to understand the concepts of cloud computing Students Learnt importance of Cloud Virtualization, Abstraction's, Enabling Technologies and cloud security
Reflective Critique	<ul style="list-style-type: none">• Certification courses help students show & build their expertise in courses selected• It aims students to sharpen their skill sets & prepare well for their future careers

Proofs :

https://drive.google.com/file/d/1L4N1LFn5FS2xpm4G7V1nLf_L-1HOZvgF/view?usp=sharing

Sample copy of the certificate attached





K.S. INSTITUTE OF TECHNOLOGY, BANGALORE - 560109
DEPARTMENT OF COMPUTER SCIENCE AND ENGINEERING
TEACHING AND LEARNING

CONTENT BEYOND SYLLABUS REPORT

Academic Year	2024-2025(EVEN)
Name of the Faculty	PRASHANTH H S
Course Name /Code	CLOUD COMPUTING/BCS601
Semester/Section	VI C
Activity Name	INFOSYS SPRINGBOARD: CERTIFICATE
Topic Covered	Module 1: Distributed System Models and Enabling Technologies Module 2: Virtual Machines and Virtualization of Clusters and DataCentres Module 3: Cloud Platform Architecture over Virtualized Datacentres Module 4: Cloud Security Module 5: Cloud Programming and Software Environments
No. of Participants	66
Objectives/Goals	<ul style="list-style-type: none">• Introduce the rationale behind the cloud computing revolution and the business drivers• Understand various models, types and challenges of cloud computing• Understand the design of cloud native applications, the necessary tools and the design trade-offs.• Realize the importance of Cloud Virtualization, Abstraction's, Enabling Technologies and cloud security.
ICT Used	Google forms
Appropriate Method/Instructional Materials/Exam Questions	The students of the class were provided with the following: <ol style="list-style-type: none">1. Distributed System Models and Enabling Technologies2. Virtual Machines and Virtualization of Clusters and Data Centers3. Cloud Platform Architecture over Virtualized Datacenters4. Cloud Security and Trust Management5. Cloud Programming and Software Environments
Relevant CO's	CO1,CO2,CO3,CO4,CO5
Relevant PO's:	PO1,PO2,PO4,PO5,PO12
Significance of Results/Outcomes	<ul style="list-style-type: none">• Students were able to understand the impact of cloud computing across technology, business, and society.
Reflective Critique	<ul style="list-style-type: none">• The main goal of a Cloud Computing quiz is to assess students' understanding and application of fundamental concepts, architectures, technologies, and real-world implications of cloud computing.
Proofs :	
Sample copy of the certificate attached	
https://drive.google.com/drive/folders/1AgjPOFPgC2PgPAF39jg6A6Hw6MH3Rck44GG5M-_gdkxaSZFaywtbB77ghk15mo6XJo31fIFS?usp=drive_link	



COURSE COMPLETION CERTIFICATE

The certificate is awarded to

Siri Gowda

for successfully completing the course

Cloud Computing

on May 16, 2025

Infosys | Springboard

Congratulations! You make us proud!

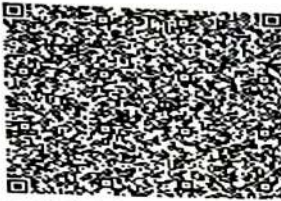

Issued on: Saturday, May 17, 2025
To verify, scan the QR code at <https://verify.oninfosys.com>

Thirumala Arohi
Executive Vice President and Global Head
Education, Training & Assessment (ETA)
Infosys Limited



COURSE COMPLETION CERTIFICATE

The certificate is awarded to

Shreya P R

for successfully completing the course

Virtualization and Cloud Computing

on May 19, 2025

Infosys | Springboard

Congratulations! You make us proud!

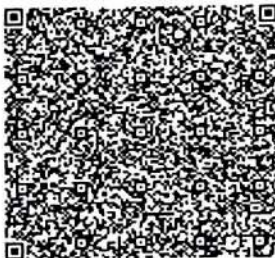

Issued on: Thursday, May 22, 2025
To verify, scan the QR code at <https://verify.onwingspan.com>

Thirumala Arohi
Executive Vice President and Global Head
Education, Training & Assessment (ETA)
Infosys Limited

Signature of Course In charge

Signature of HOD



K.S. INSTITUTE OF TECHNOLOGY, BANGALORE - 560109
DEPARTMENT OF COMPUTER SCIENCE AND ENGINEERING
TEACHING AND LEARNING
CONTENT BEYOND SYLLABUS REPORT

Academic Year	2024-25
Name of the Faculty	SWAPNA SUBHASH BANASODE
Course Name /Code	Machine Learning (BCS602)
Semester/Section	VI/ 'A'
Activity Name	Online Certification (Infosys Springboard)
Topic Covered	Machine Learning Fundamentals
No. of Participants	56
Objectives/Goals	To help students understand the basics of machine learning
ICT Used	E-Learning
Appropriate Method/Instructional Materials/Exam Questions: Infosys Springboard: Machine Learning Fundamentals Getting Started with Machine Learning	
Relevant CO's	CO1,CO2,CO3,CO4,CO5
Relevant PO's:	PO1,PO2, PO3,PO4,PO5,PO6,PO7,PO8,PO10,PO12
Significance of Results/Outcomes	Students were able to understand <ul style="list-style-type: none">• Introduction to Scikit-Learn• Unsupervised Learning: Real-life Applications• Supervised Learning: Key Steps• Supervised Learning Algorithms: Predict Annual Income• Artificial Neural Networks: Predict Annual Income• Building Your Own Program
Reflective Critique	<ul style="list-style-type: none">• Certification courses help students to show and build their expertise in Course selected.• Certification courses aim to help students sharpen their skill sets and prepare for the workplace.• The activity provided a platform for students to apply their knowledge in Research oriented work.

<https://drive.google.com/drive/folders/1yKv56ZG1bHEFkrj2OmDwFzpkSVKj-3fz>

Sample copy of the certificate attached here

Infosys
Navigate your next

Adithya M
IKS 22CS004

||||| COURSE COMPLETION CERTIFICATE |||||

The certificate is awarded to
Adithya M
for successfully completing the course
Machine Learning Fundamentals
on May 9, 2025

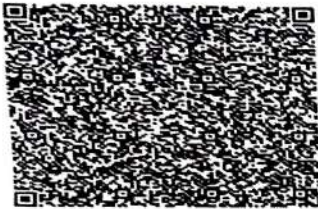

Issued on: Saturday, May 10, 2025
To verify, scan the QR code at <https://verify.ouwingspan.com>

Infosys | Springboard

Congratulations! You make us proud!

Thirumala Arohi
Executive Vice President and Global Head
Education, Training & Assessment (ETA)
Infosys Limited

Bindu M
IKS22CS028

Certificate no: UC-bc510fbc-9b7f-4249-877a-fa16c37e269
Certificate url: ude.my/UC-bc510fbc-9b7f-4249-877a-fa16c37e269
Reference Number: 0004

Udemy

CERTIFICATE OF COMPLETION

**Machine Learning Essentials
- Master core ML concepts**

Instructors **Mohit Uniyal, Prateek Narang Sr. Software Engineer Google**

Bindu M
Date **May 17, 2025**
Length **28 total hours**

Signature of Course In charge

Signature of HOD



K.S. INSTITUTE OF TECHNOLOGY, BANGALORE - 560109
DEPARTMENT OF COMPUTER SCIENCE AND ENGINEERING
TEACHING AND LEARNING

CONTENT BEYOND SYLLABUS REPORT

Academic Year	2024-25
Name of the Faculty	ROOPASHREE S V
Course Name /Code	MACHINE LEARNING (BCS602)
Semester/Section	6 "B"
Activity Name	Value Added Course
Topic Covered	Machine learning
No. of Participants	69
Objectives/Goals	<ul style="list-style-type: none">• To introduce the fundamental concepts and techniques of machine learning.• To understanding of various types of machine learning and the challenges faced in real world applications.• To familiarize the machine learning algorithms such as regression, decision trees, Bayesian models, clustering, and neural networks.• To explore advanced concept like reinforcement learning and provide practical insight into its applications.• To enable students to model and evaluate machine learning solutions for different types of problems.
ICT Used	E-Learning
Appropriate Method/Instructional Materials/Exam Questions: The students of the class were provided with the following : <ol style="list-style-type: none">1. Project-Based Learning2. Lectures and Presentations3. Discussion and Group Work4. Visualizations and Interactive Tools	
Relevant CO's	CO1, CO2, CO3, CO4, CO5.
Relevant PO's:	PO1, PO2, PO3, PO4, PO5, PO6, PO12.
Significance of Results/Outcomes	Students were able to understand the Machine learning concepts.
Reflective Critique	Earning a machine learning certification marks a key milestone, but continuous reflection and learning are essential for further growth and mastery in this evolving field.
Proofs : https://drive.google.com/drive/folders/11QZ6lsmYACBhMoBakuD1iqIOBeBxztdH?usp=drive link	
Sample copy of the certificate attached	



COURSE COMPLETION CERTIFICATE

The certificate is awarded to

Manasvi H Y

for successfully completing the course

HandsOn Problem Solving for Machine Learning

on June 1, 2025

Infosys | Springboard

Congratulations! You make us proud!



Issued on: Monday, June 2, 2025
To verify, scan the QR code at <https://infosys.com/certificates>

Thirumala Arohi
Executive Vice President and Global Head
Education, Training & Assessment (ETA)
Infosys Limited



COURSE COMPLETION CERTIFICATE

The certificate is awarded to

Pruthu KL

for successfully completing the course

Introduction to Machine Learning

on June 1, 2025

Infosys | Springboard

Congratulations! You make us proud!

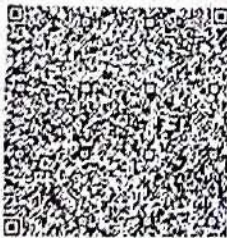

Issued on: Monday, June 2, 2025
To verify, scan the QR code at <https://infosys.com/certificates>

Thirumala Arohi
Executive Vice President and Global Head
Education, Training & Assessment (ETA)
Infosys Limited

Signature of Course In charge

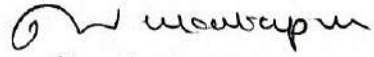
Signature of HOD
Head of the Department
Dept. of Computer Science & Engg
K.S. Institute of Technology
Bengaluru -560 109



K. S. Institute of Technology, BANGLORE

DEPARTMENT OF COMPUTER SCIENCE AND ENGINEERING

ONLINE COURSE-Infosys Springboard-certifications completed by students

ACADEMIC YEAR 2023-24 EVEN SEM

Year/Semester/Section: III/VI/B

SL. No	USN	Students name	Platform	Details of Certification	Date
1	1KS22CS063	KRUTHANVA R	Infosys Springboard	Introduction to Machine learning	2/6/2025
2	1KS22CS064	KUSHI M	Infosys Springboard	Hands on Problem solving for Machine learning	01/06/2025
3	1KS22CS065	L DEEKSHA	Infosys Springboard	Hands on Problem solving for Machine learning	01/06/2025
4	1KS22CS066	L SHREYAS SRINIVAS	Infosys Springboard	Introduction to Machine learning	1/6/2025
5	1KS22CS067	LAKSHMI SHREE K P	Infosys Springboard	Introduction to Machine learning	1/6/2025
6	1KS22CS068	LALITHYA S	Infosys Springboard	Hands on Problem solving for Machine learning	01/06/2025
7	1KS22CS069	LEKHANA L	Infosys Springboard	Mathematical and Statistics Foundations for Machine learning	25/5/2025
8	1KS22CS070	LIKHITH K	Infosys Springboard	Introduction to Machine learning	1/6/2025
9	1KS22CS071	LIPIKA J	Infosys Springboard	Hands on Problem solving for Machine learning	01/06/2025
10	1KS22CS072	M ASHRITHA	Infosys Springboard	Hands on Problem solving for Machine learning	01/06/2025
11	1KS22CS073	M N AMOGH ATHREYA	Infosys Springboard	Introduction to Machine learning	2/6/2025
12	1KS22CS074	MADDURI YAVANIKA	Infosys Springboard	Hands on Problem solving for Machine learning	01/06/2025
13	1KS22CS075	MALLIKARJUN K S	Infosys Springboard	Introduction to Machine learning	1/6/2025
14	1KS22CS076	MANASVI H Y	Infosys Springboard	Hands on Problem solving for Machine learning	01/06/2025
15	1KS22CS077	MANOJA G V	Infosys Springboard	Introduction to Machine learning	1/6/2025
16	1KS22CS078	MEGHA S	Infosys Springboard	Machine learning in Sage maker	1/6/2025
17	1KS22CS079	MINAKSHI ANIL BADIFER	Simply Learn	Introduction to Machine learning	2/6/2025
18	1KS22CS080	MISBA SABA	Infosys Springboard	Introduction to Machine learning	1/6/2025

19	1KS22CS081	MOHAMMED TAHIR	Infosys Springboard	Introduction to Machine learning	1/6/2025
20	1KS22CS082	MOHAMMED YAHYA NAZIM	Infosys Springboard	Introduction to Machine learning	1/6/2025
21	1KS22CS083	MOKESH G R	Infosys Springboard	Introduction to Machine learning	1/6/2025
22	1KS22CS084	MONIKA H	Infosys Springboard	Machine learning Fundamentals	10/5/2025
23	1KS22CS085	MONIKA V	Infosys Springboard	Introduction to Machine learning	1/6/2025
24	1KS22CS086	MONISHA C	Simply Learn	Introduction to Machine learning	2/6/2025
25	1KS22CS087	NAGAMA HESH KENDOLE	Infosys Springboard	Introduction to Machine learning	2/6/2025
26	1KS22CS088	NAGAMMA	Infosys Springboard	Introduction to Machine learning	25/5/2025
27	1KS22CS089	NAGARJUN KUMAR S	Infosys Springboard	Introduction to Machine learning	1/6/2025
28	1KS22CS090	NARESH KUMAR N	Infosys Springboard	Introduction to Machine learning	1/6/2025
29	1KS22CS091	NAWAZ KHAN	Infosys Springboard	Introduction to Machine learning	1/6/2025
30	1KS22CS092	NAYANA R	Infosys Springboard	Introduction to Machine learning	1/6/2025
31	1KS22CS093	NEHA V	Infosys Springboard	Introduction to Machine learning	1/6/2025
32	1KS22CS094	NITHIN R	Infosys Springboard	Introduction to Machine learning	1/6/2025
33	1KS22CS095	P C TEJAS	Infosys Springboard	Introduction to Machine learning	1/6/2025
34	1KS22CS096	PAAVANA P	Infosys Springboard	Hands on Problem solving for Machine learning	01/06/2025
35	1KS22CS097	PALLAVI C	Infosys Springboard	Hands on Problem solving for Machine learning	01/06/2025
36	1KS22CS098	PALLAVI S	Udemy	Introduction to Machine learning	1/6/2025
37	1KS22CS099	PANCHAMI L	Simply Learn	Introduction to Machine learning	2/6/2025
38	1KS22CS100	PARVEZ ANSARI	Infosys Springboard	Introduction to Machine learning	1/6/2025
39	1KS22CS101	PASUPULETI SRAVYA	Infosys Springboard	Hands on Problem solving for Machine learning	01/06/2025
40	1KS22CS102	POOJITHA J N	Infosys Springboard	Introduction to Machine learning	1/6/2025
41	1KS22CS103	POONAM SINGH A	Udemy	Introduction to Machine learning	1/6/2025
42	1KS22CS104	PRAJNA ANANT GAONKAR	IBM	Introduction to Machine learning	2/6/2025
43	1KS22CS105	PRAKRUTHI G P	Infosys Springboard	Introduction to Machine learning	1/6/2025
44	1KS22CS106	PRANAV B R	Udemy	Introduction to Machine learning	1/6/2025
45	1KS22CS107	PREETHAL D SOUZA	Infosys Springboard	Introduction to Machine learning	1/6/2025

46	IKS22CS108	PRUTHU K L	Infosys Springboard	Machine learning Beginner	1/6/2025
47	IKS22CS109	PUNEETH VEMURI	Infosys Springboard	Introduction to Machine learning	1/6/2025
48	IKS22CS110	R CHENDRA CHUDA	Infosys Springboard	Introduction to Machine learning	25/5/2025
49	IKS22CS111	RACHANA N	Infosys Springboard	Introduction to Machine learning	1/6/2025
50	IKS22CS112	RAGHUSAI ACHUT	Infosys Springboard	Introduction to Machine learning	1/6/2025
51	IKS22CS113	RAKSHITHA A U	Infosys Springboard	Mathematical and Statistics Foundations for Machine learning	2/5/2025
52	IKS22CS114	RAKSHITHA J	Infosys Springboard	Introduction to Machine learning	1/6/2025
53	IKS22CS115	RAKSHITHA R	Infosys Springboard	Explore Machine Learning using Python	2/6/2025
54	IKS22CS116	RAVI SHANKAR D M	Infosys Springboard	Machine & Deep learning Algorithms	2/6/2025
55	IKS22CS117	RENUKA CHOWDARY	Infosys Springboard	Hands on Problem solving for Machine learning	01/06/2025
56	IKS22CS118	REVANTH RAJ P	Infosys Springboard	Introduction to Machine learning	1/6/2025
57	IKS22CS119	RINI JAIN H P	Infosys Springboard	Introduction to Machine learning	2/6/2025
58	IKS22CS120	RUCHITHA S	Infosys Springboard	Machine learning	2/6/2025
59	IKS22CS121	RUSHIL RUTHVIGNA	Infosys Springboard	Introduction to Machine learning	1/6/2025
60	IKS22CS122	RUTVIK CHANDRA M	Infosys Springboard	Introduction to Machine learning	1/6/2025
61	IKS22CS123	S HYMA	Infosys Springboard	Introduction to Machine learning	1/6/2025
62	IKS22CS124	MANOJ S	Infosys Springboard	Introduction to Machine learning	1/6/2025
63	IKS22CS125	SACHIN SOMASHEKHAR KUMBAR	Infosys Springboard	Introduction to Machine learning	1/6/2025
64	IKS22CS191	LAKSHMI P	Infosys Springboard	Hands on Problem solving for Machine learning	01/06/2025
65	IKS23CS402	DARSHAN T V	Infosys Springboard	Introduction to Machine learning	1/6/2025
66	IKS23CS403	GAGANA P	Infosys Springboard	Introduction to Machine learning	1/6/2025
67	IKS23CS404	GAGANA SHREE M S	Infosys Springboard	Introduction to Machine learning	1/6/2025
68	IKS23CS412	SHARATH Y	Infosys Springboard	Introduction to Machine learning	1/6/2025
69	IKS23CS414	SYED FARHAN	Infosys Springboard	Explore Machine Learning using Python	2/6/2025



CONTENT BEYOND SYLLABUS REPORT

Academic Year	2024-2025(even)
Name of the Faculty	Mrs Beena K
Course Name /Code	Machine Learning / BCS602
Semester/Section	6 th C
Activity Name	Online Certification (Infosys Springboard)
Topic Covered	Machine Learning
No. of Participants	66
Objectives/Goals	<ul style="list-style-type: none">• To understand the topic more precisely• To improve the self-learning skills of students
ICT Used	E-Learning
Appropriate Method/Instructional Materials/Exam Questions: Infosys Springboard: Machine Learning	
Relevant CO's	CO1,CO2,CO3,CO4,CO5
Relevant PO's:	PO9, PO10 ,PO12
Significance of Results/Outcomes	<ul style="list-style-type: none">• Students were able to understand the Machine Learning applications
Reflective Critique	<ul style="list-style-type: none">• Certification courses help students show and build their expertise in <i>Courses selected</i>• Certification courses aim to help students sharpen their skill set and prepare for the workplace.• The activity provided a platform for students to apply their knowledge of ML.
Drive link: https://drive.google.com/drive/folders/1erkkj-sZCZkboP206Xjgs_LkJcr5lzX2	
Proofs : Sample copy of the certificate attached	



COURSE COMPLETION CERTIFICATE

The certificate is awarded to

Thanuja Thalapaneni

for successfully completing the course

Machine Learning with SciKit-Learn in Python

on May 9, 2025

Infosys | Springboard

Congratulations! You make us proud!

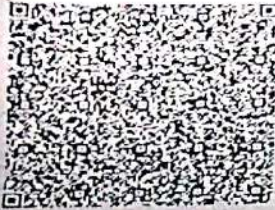

Issued on: Sunday, May 11, 2025
To verify, scan the QR code at <https://verify.onspringboard.com>

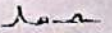
Thirumala Archi
Executive Vice President and Global Head
Education, Training & Assessment (ETA)
Infosys Limited



COURSE COMPLETION CERTIFICATE

The certificate is awarded to

Thejus k

for successfully completing the course

Mathematical and Statistics Foundations for Machine Learning

on May 29, 2025

Infosys | Springboard

Congratulations! You make us proud!

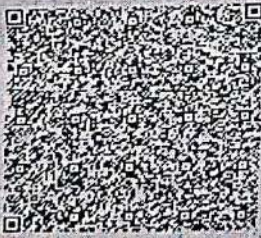

Issued on: Friday, May 30, 2025
To verify, scan the QR code at <https://verify.onspringboard.com>

Thirumala Archi
Executive Vice President and Global Head
Education, Training & Assessment (ETA)
Infosys Limited

Signature of Course In charge

Signature of HOD





K.S. INSTITUTE OF TECHNOLOGY, BANGALORE - 560109
DEPARTMENT OF COMPUTER SCIENCE AND ENGINEERING
TEACHING AND LEARNING

CONTENT BEYOND SYLLABUS REPORT

Academic Year	2024-2025(Even)
Name of the Faculty	Dr.Sunita Chalageri
Course Name /Code	Compiler Design(BCS613C)
Semester/Section	6 th
Activity Name	Online Certification (NPTEL ,Eurpean Academy)
Topic Covered	Compiler Design
No. of Participants	32/60
Objectives/Goals	<ul style="list-style-type: none">To understand the topic more preciselyTo improve the self-learning skills of students
ICT Used	E-Learning
Appropriate Method/Instructional Materials/Exam Questions: NPTEL: Compiler Design Eurpean Academy: Compiler Design	
Relevant CO's	CO1,CO2,CO3,CO4,CO5
Relevant PO's:	PO9, PO10,PO12
Significance of Results/Outcomes	<ul style="list-style-type: none">Students were able to understand the Concepts of Compiler Design and its applications.
Reflective Critique	<ul style="list-style-type: none">Certification courses help students show and build their expertise in <i>Courses selected</i>Certification courses aim to help students sharpen their skill sets and prepare for the workplace.The activity provided a platform for students to apply their knowledge of Compiler Design
Proofs : Sample copy of the certificate attached	

CERTIFICATE

This certifies that

Lakshmi Shree K P

has satisfactorily completed the course of study in

Compiler Design

PROFESSIONAL CERTIFICATE PROGRAM

Awarded Date

April 19, 2025

Ursula Hermann
President, European Open University



Ursula Hermann
President, European Open University



NPTEL ONLINE CERTIFICATION

(Funded by the MoE, Govt. of India)



This certificate is awarded to

ANMOL NAIK S

for successfully completing the course

Compiler Design



with a consolidated score of **50 %**

Online Assignments	10.88/25	Proctored Exam	39/75
--------------------	----------	----------------	-------

Total number of candidates certified in this course: 2757

Jan-Apr 2025

(12 week course)

Prof. Rajmouli Banerji
Coordinator, NPTEL
IIT Kharagpur



Indian Institute of Technology Kharagpur



Roll No. NPTEL25CS1351142200526

To verify the certificate



No. of credits recommended: 3 or 4

[Signature]

Signature of Course In charge

[Signature]

Signature of HOD



CONTENT BEYOND SYLLABUS REPORT

Academic Year	2024-2025(Even)
Name of the Faculty	Dr. Sowbhagya M P
Course Name /Code	Compiler design(BCS613C)
Semester/Section	6 th
Activity Name	Online Certification
Topic Covered	Compiler design
No. of Participants	28/35
Objectives/Goals	<ul style="list-style-type: none">• To understand the topic more precisely• To improve the self-learning skills of students
ICT Used	E-Learning
Appropriate Method/Instructional Materials/Exam Questions: NPTEL: Compiler Design	
Relevant CO's	CO1,CO2,CO3,CO4,CO5
Relevant PO's:	PO9, PO10 ,PO12
Significance of Results/Outcomes	<ul style="list-style-type: none">• Students were able to understand the Concepts of Compiler design and its application.
Reflective Critique	<ul style="list-style-type: none">• Certification courses help students show and build their expertise in <i>Courses selected</i>• Certification courses aim to help students sharpen their skill sets and prepare for the workplace.• The activity provided a platform for students to apply their knowledge of Compiler Design.
Proofs : Sample copy of the certificate attached	

Elite



NPTEL ONLINE CERTIFICATION
(Funded by the MoE, Govt. of India)

This certificate is awarded to
VIDYA M S
for successfully completing the course
Compiler Design
with a consolidated score of **63 %**

Online Assignments	24/19/25	Proctored Exam	39/75
--------------------	----------	----------------	-------

Total number of candidates certified in this course: **2757**

Jan-Apr 2025
(12 week course)



Skill India
atishya krishna - gurav krishna





Indian Institute of Technology Kharagpur



CERTIFICATE OF ACHIEVEMENT

This certificate is presented to
LEKHNA L
for successfully completing a Course about

Compiler Design Principles

Course Start Date: 2025-05-21

Certified No.
7ecce19e

Course Duration 6 hours

 **Mind Luster**
mindluster
Signature



www.mindluster.com

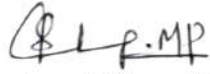

2025-05-21
Date

Signature of Course In charge

Signature of HOD
Head of the Department
Dept. of Computer Science & Engg
K.S. Institute of Technology
Bengaluru -560 109



CONTENT BEYOND SYLLABUS REPORT

Academic Year	2024-2025(Even)
Name of the Faculty	Mr. Abhilash L Bhat
Course Name /Code	Advanced Java (BCS613D)
Semester/Section	6th A
Activity Name	Online Certification (Infosys Springboard)
Topic Covered	Advanced Java Concepts
No. of Participants	45/45
Objectives/Goals	<ul style="list-style-type: none">• To understand the topic more precisely• To improve the self-learning skills of students
ICT Used	E-Learning
Appropriate Method/Instructional Materials/Exam Questions: <ul style="list-style-type: none">• Infosys Springboard: Advanced Java Concepts.	
Relevant CO's	CO1, CO2, CO3, CO4, CO5
Relevant PO's:	PO9, PO10
Significance of Results/Outcomes	<ul style="list-style-type: none">• Students were able to understand the Advanced Java Concepts which helps them to develop applications.
Reflective Critique	<ul style="list-style-type: none">• Certification courses help students show and build their expertise in <i>Courses selected</i>• Certification courses aim to help students sharpen their skill sets and get prepared for the workplace.• The activity provided a platform for students to apply their knowledge of Advanced Java.

Proofs: https://drive.google.com/drive/folders/11WeEO_2iFauCfj2z4qt7Wq9UusjrrtfH

Sample copy of the certificate attached

003



COURSE COMPLETION CERTIFICATE

The certificate is awarded to

Achyutha U N

for successfully completing the course

Java AWT with Projects and Case Studies

on June 1, 2025

Infosys | Springboard

Congratulations! You make us proud!

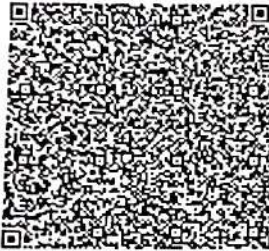

Issued on: Monday, June 2, 2025
To verify, scan the QR code at <https://verify.springboard.com>

Thirumala Arohi
Executive Vice President and Global Head
Education, Training & Assessment (ETA)
Infosys Limited

Signature of Course In charge

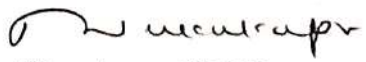
Signature of HOD
Head of the Department
Dept. of Computer Science & Engg
K.S. Institute of Technology
Bengaluru -560 109



CONTENT BEYOND SYLLABUS REPORT

Academic Year	2024-2025
Name of the Faculty	V Manjula
Course Name /Code	Renewable Energy Power Plants(BME654B)
Semester/Section	VI/B
Activity Name	INFOSYS SPRINGBOARD/Udemy: CERTIFICATE COURSE
Topic Covered	To understand the natural resources more precisely. To understand the concepts of solar energy. To understand the concepts and applications of alternative energy sources. To get exposed to energy conservation methods.
No. of Participants	69
Objectives/Goals	Students have to improve their skills other than the subject, know about online certifications
ICT Used	E-Learning
Appropriate Method/Instructional Materials/Exam Questions: Infosys Springboard/Udemy : Renewable Energy Power Plant	
Relevant CO's	CO1,CO2,CO3,CO5.
Relevant PO's:	PO: PO2,PO3,PO5,PO9,PO10,PO11,P12
Significance of Results/Outcomes	Students were able to understand the concepts of energy sources
Reflective Critique	The main goal of QUIZ is how well students understand concepts and will be able to manage the time.

Proofs : <https://forms.gle/s9bqA12zoWX7xZOPA>

Sample copy of the certificate attached



COURSE COMPLETION CERTIFICATE

The certificate is awarded to
LAKSHMI SHREE K P
for successfully completing the course
Sustainability: Clean, Green Energy Choices
on May 13, 2025



Infosys | Springboard



COURSE COMPLETION CERTIFICATE

The certificate is awarded to
Megha S
for successfully completing the course
Sustainability: Clean, Green Energy Choices
on May 19, 2025



Infosys | Springboard

Signature of Course In charge

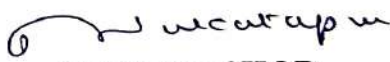
Signature of HOD
Head of the Department
Department of Computer Science & Engg
K.S. Institute of Technology
Bengaluru -560 109